

MT 182

Assembly & maintenance exercise: screw pump



The illustration shows the tool box with kit and tools. The fully assembled pump is shown in the foreground.

Description

- **practical exercise on the assembly and maintenance of a screw pump**
- **part of the GUNT Practice Line for assembly, maintenance and repair**

Screw pumps are positive displacement pumps and operate in a rotary manner, normally primed. The pump presented here can be used for a number of different fluids. These include any non-aggressive fluids with lubricating properties, with viscosities between 2...1500mm²/s, such as lubricating oil, vegetable oil, hydraulic fluid, glycols, polymers and emulsions. Typical applications include: lubricating diesel motors; gears; gas, steam and water turbines; and cooling and filtration circuits in large-scale machines and hydraulic systems.

The MT 182 kit forms part of the GUNT Practice Line for assembly, maintenance and repair designed for training at technical colleges and in company training centres.

A close link between theory and practice is key to the learning content. The kit is ideally suited to project-based learning with a particular emphasis on 'hands-on' work. Independent working by the students is assisted and encouraged. Learning in a small team offers a useful learning format.

MT 182 enables a typical screw pump to be assembled and maintained. Students become familiar with all the pump components and their modes of operation. The parts are clearly laid out in a toolbox. Systematic assembly and disassembly of a pump is practiced.

The accompanying material details the individual steps involved in the exercise, and provides additional information on the areas of application, mode of operation and design of the pump.

Learning objectives/experiments

- design and function of a screw pump and its components
- assembly and disassembly for maintenance and repair purposes
- replacing components (e.g. seals)
- troubleshooting, fault assessment
- planning and assessment of maintenance and repair operations
- reading and understanding engineering drawings and operating instructions

MT 182

Assembly & maintenance exercise: screw pump

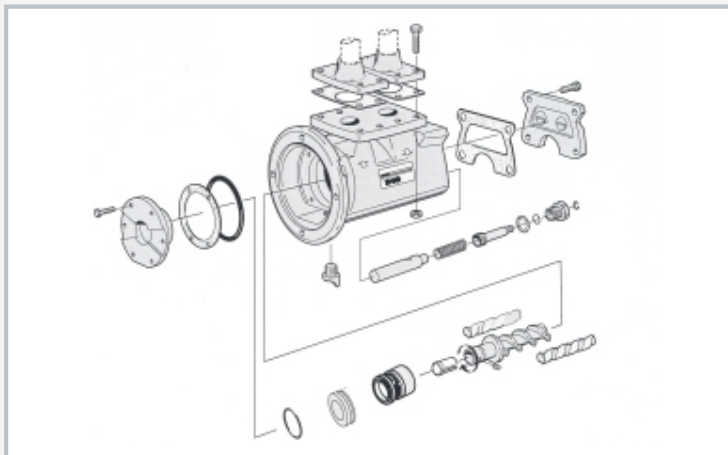

Exploded-view drawing of the screw pump

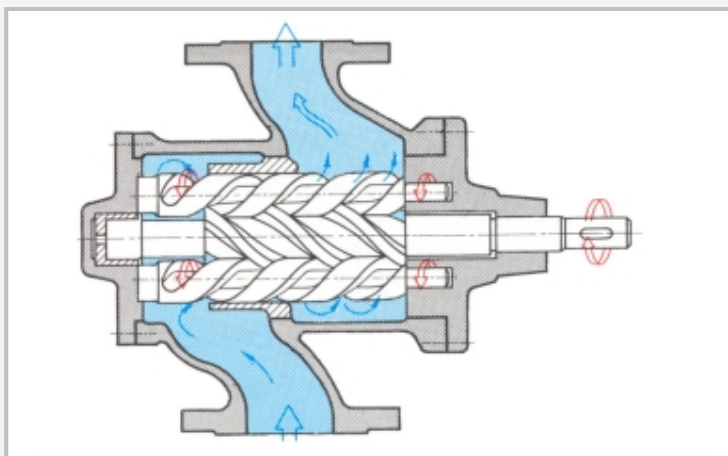

Principle of operation of the screw pump



Assembly of the screw pump: assembling the valve piston with the valve spring

Specification

- [1] learning concept for maintenance and repair exercises on a screw pump
- [2] three-spindle screw pump with 1 driving spindle and 2 delivery spindles
- [3] integrated pressure limiting valve; at overpressures a portion of the flow is returned to the intake side
- [4] used for media with a kinematic viscosity in the range 2...1500mm²/s
- [5] pump parts and tools housed contained in a tool box
- [6] part of the GUNT Practice Line for assembly, maintenance and repair

Technical data

Screw pump

- power consumption: max. 1350W
- max. head: 12bar
- displacement: 13,9cm³/spindle revolution
- max. speed: 3600min⁻¹
- intake connection: DN25
- delivery connection: DN25
- grey cast iron housing

LxWxH: 690x360x312mm (tool box)

Weight: approx. 50kg

Scope of delivery

- 1 kit
- 1 set of tools
- 1 set of small parts
- 1 set of gaskets
- 1 tool box with foam inlay
- 1 set of instructional material, consisting of: technical description of system, complete set of drawings with lists of parts, description of maintenance and repair processes, suggested exercises; manufacturer's manual