

# MT 185

## Assembly & maintenance exercise: in-line centrifugal pump



The illustration shows the box with kit, the fully assembled pump is shown in the foreground

### Description

- **practical exercise on the assembly and maintenance of an in-line centrifugal pump**
- **part of the GUNT Practice Line for assembly, maintenance and repair**

In-line centrifugal pumps are rotodynamic pumps and operate normally primed. In-line pumps are installed in the straight runs of pipelines. The difference between an in-line pump and a standard pump is that the intake and delivery connections of an in-line pump are aligned on a single axis.

The in-line centrifugal pump presented here is used to pump mechanically and chemically non-aggressive liquids. Its range of applications include use in water supply, irrigation and sprinkler systems, and heating engineering systems.

The MT 185 kit forms part of the GUNT Practice Line for assembly, maintenance and repair designed for training at technical colleges and in company training centres.

A close link between theory and practice is key to the learning content. The kit is ideally suited to project-based learning with a particular emphasis on 'hands-on' work. Independent working by the students is assisted and encouraged. Performing exercises in a small team offers a useful learning format.

MT 185 enables a typical in-line centrifugal pump to be assembled and maintained. Students become familiar with all the pump components and their modes of operation. The parts are clearly laid out in a tool box. Systematic assembly and disassembly of a pump is practiced.

The instruction material details the individual steps involved in the exercise, and provides additional information on the areas of application, mode of operation and design of the pump.

### Learning objectives/experiments

- design and function of an in-line centrifugal pump and its components
- assembly and disassembly for maintenance and repair purposes
- replacing components (e.g. seals)
- troubleshooting, fault assessment
- planning and assessment of maintenance and repair operations
- reading and understanding engineering drawings and operating instructions

# MT 185

## Assembly & maintenance exercise: in-line centrifugal pump

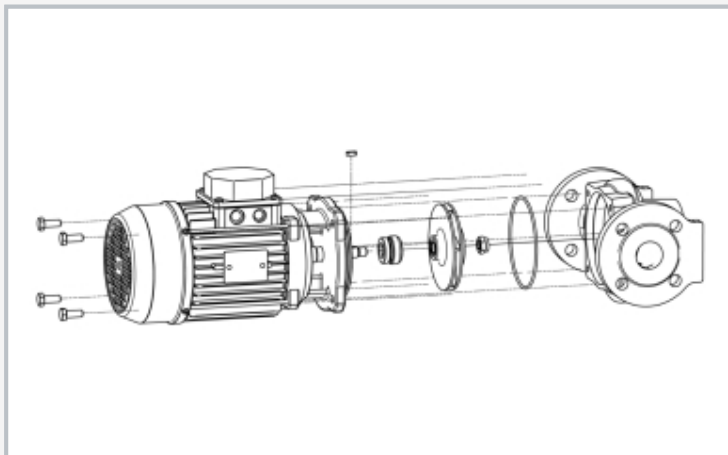

Exploded-view drawing of the in-line centrifugal pump

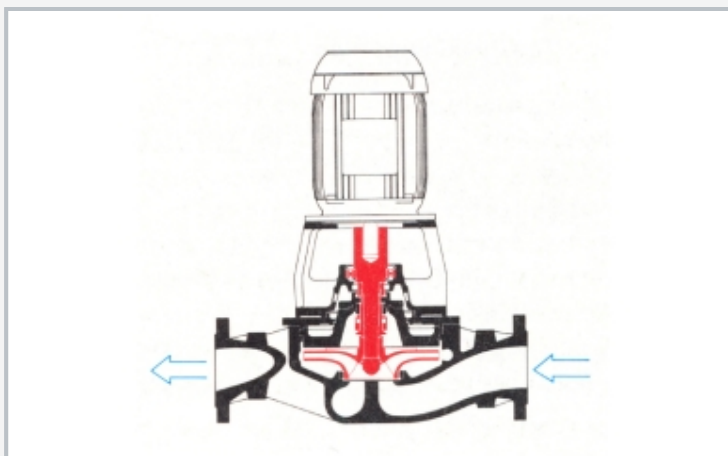

In-line centrifugal pump: intake and delivery connections on the same axis

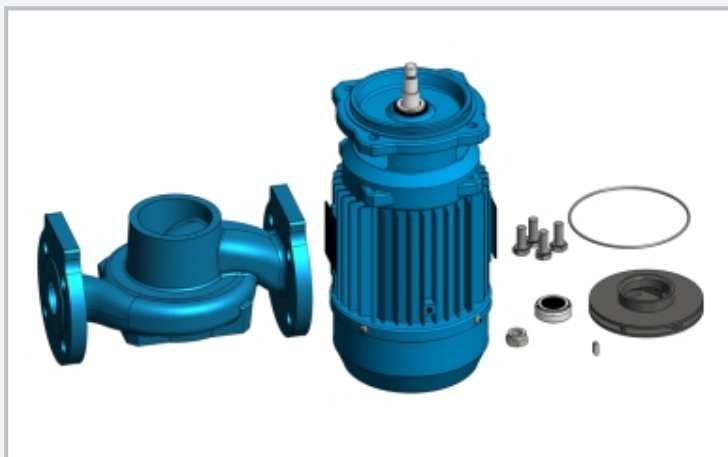

Individual parts of the in-line centrifugal pump

### Specification

- [1] learning concept for maintenance and repair exercises on an in-line centrifugal pump
- [2] enclosed pump impeller with 6 blades, designed for pure liquids
- [3] pump shaft sealing with floating ring seal
- [4] pump drive by 3-phase AC motor
- [5] pump parts and tools housed in a tool box
- [6] part of the GUNT Practice Line for assembly, maintenance and repair

### Technical data

In-line centrifugal pump

- power consumption: max. 370W
- max. flow rate: 13m<sup>3</sup>/h
- max. head: 11 m
- speed: 2830min<sup>-1</sup>
- intake connection: DN32
- delivery connection: DN32
- housing: grey cast iron
- impeller: GRP

Drive motor

- 400V, 50Hz, 3 phases; or 230V, 60Hz, 3 phases

LxWxH: 690x360x310mm (tool box)

Weight: approx. 28kg

### Scope of delivery

- 1 kit
- 1 set of tools
- 1 set of small parts
- 1 set of gaskets
- 1 tool box with foam inlay
- 1 set of instructional material, consisting of: technical description of system, complete set of drawings with lists of parts, description of maintenance and repair processes, suggested exercises; manufacturer's manual