

# RT 580

## Control systems and fault finding



screen mirroring is possible on different end devices

### Description

- practical control of level, flow rate and temperature including simulation of typical faults via PLC
- plant control and configuration via touch screen
- integrated router for operation and control via an end device and for screen mirroring on additional end devices: PC, tablet, smartphone
- refrigeration system for independent cold supply

The RT 580 facilitates practical learning in the control of three controlled variables which are commonplace in process engineering.

A circuit with a collecting tank, pump and graduated tank is provided for control of level and flow rate. A pneumatic control valve is used as the actuator. There is a valve in the tank outlet to generate a disturbance variable in level control. Cascade control is possible whereby the level in the tank is controlled by way of the flow rate.

Two circuits are used in the control of the temperature. A refrigeration system cools the water in the collecting tank. A pump circulates the water via a heat exchanger (cooling circuit). A heater heats the water in the graduated tank. Another pump also circulates the warm water via the heat exchanger. In the heat exchanger the water in the cooling circuit is heated. The

controlled variable is the temperature of the water in the cooling circuit after heating in the heat exchanger. The actuator is the pneumatic control valve which adjusts the flow rate of the warm water. Cascade control is also possible to control the temperature.

The trainer is equipped with a comprehensive range of functions for measurement, control and operation that are controlled by a PLC: monitoring of safety devices (e.g. a low water cut-off protecting the heater), simulation of typical faults (e.g. failure of sensors or cable breaks), and three controllers which can be employed as the primary controller (master) and secondary controller (slave) in the implementation of cascade control. A touch screen displays the measured values and operating states and can be used to control the trainer. By means of an integrated router, the trainer can alternatively be operated and controlled via an end device. The user interface can also be displayed on additional end devices (screen mirroring). The measured values can be stored internally via the PLC. Access to stored measured values is possible from end devices. Via direct LAN connection the measured values can also be transmitted to a PC where they can be analysed using the GUNT software.

### Learning objectives/experiments

- familiarisation with industrial control loop components
- setup, parameterisation and configuration on the controller
- optimisation of controller settings
- level control
- flow rate control
- temperature control
- cascade control
  - ▶ level – flow rate
  - ▶ temperature – flow rate
- plotting step responses
- fault finding
- screen mirroring: mirroring of the user interface on end devices
  - ▶ menu navigation independent of the user interface shown on the touch screen
  - ▶ different user levels available on the end device: for observing the experiments or for operation and control

# RT 580

## Control systems and fault finding



1 stirred tank with heater, 2 main circuit pump, 3 collecting tank, 4 control valve, 5 flow rate sensor, 6 refrigeration system, 7 touch screen, 8 switch cabinet, 9 flow meter, 10 heat exchanger

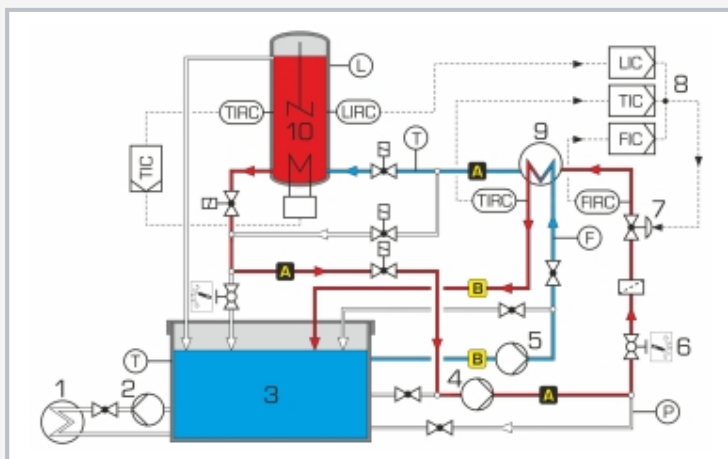

1 refrigeration system evaporator, 2 refrigeration system pump, 3 collecting tank, 4 main circuit pump circuit (A), 5 cooling circuit pump (B), 6 valve to generate disturbance variables, 7 control valve, 8 controllers, 9 heat exchanger, 10 stirred tank with heater; F flow rate, L level, P pressure, T temperature

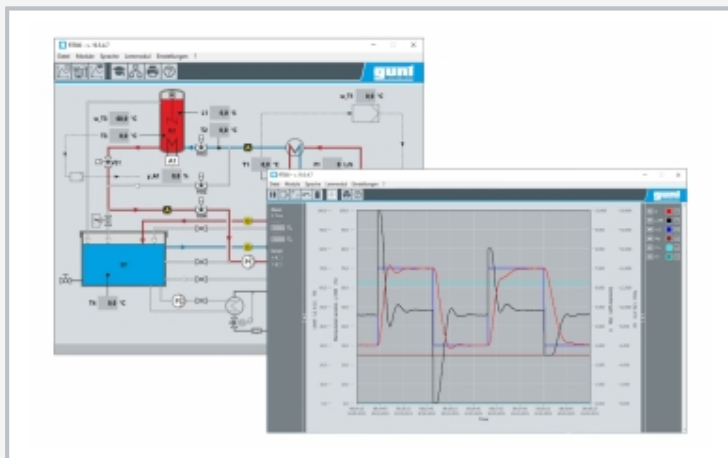

Software screenshot: level control

### Specification

- [1] control of level, flow rate, temperature and cascade control
- [2] PLC: 3 integrated controllers, monitoring of safety devices, 7 simulated faults; plant control and configuration via touch screen
- [3] integrated router for operation and control via an end device and for screen mirroring: mirroring of the user interface on up to 5 end devices
- [4] main circuit with collecting tank, graduated stirred tank with heater, pneumatic control valve and centrifugal pump
- [5] cool. circuit: pump, heat exchanger, rotameter
- [6] refr. system+pump to cool water in collecting tank
- [7] pneumatic control valve in main circuit as actuator for all controls
- [8] sensors for the measurement of the controlled variables; level, flow rate and temperature
- [9] data acquisition via PLC on internal memory, access to stored measured values via WLAN/LAN with integrated router/LAN connection to customer's own network or direct LAN connection without customer network
- [10] GUNT software for data acquisition via LAN under Windows 10
- [11] refrigerant R513A, GWP: 631

### Technical data

#### Tanks

- stirred tank with scale: approx. 10L
- collecting tank: approx. 75L

#### Main circuit centrifugal pump

- max. flow rate: approx. 4500L/h
- max. head: approx. 14m

#### 2 pumps, cooling circuit and refrigeration system

- max. flow rate: approx. 2800L/h
- max. head: approx. 4m

Heater power output: approx. 2kW

PLC: Eaton XV-303

- 3 integrated controllers parameterisable as P, PI or PID controller

Refrigerant: R513A, GWP: 631

- filling volume: 2300g
- CO<sub>2</sub>-equivalent: 1,5t

#### Measuring ranges

- level: 1x 0...600mm
- flow rate: 1x 0...2300L/h
- temperature: 4x 0...100°C
- pressure: 1x 0...2,5bar

230V, 50Hz, 1 phase; 230V, 60Hz, 1 phase

230V, 60Hz, 3 phases; UL/CSA optional

LxWxH: 2040x800x2000mm; Weight: approx. 320kg

### Required for operation

compressed air: 2...4bar; 25...50L/min  
PC with Windows recommended

### Scope of delivery

- 1 trainer, 1 GUNT software
- 1 set of instructional material