

# RT 800

## PLC application: mixing process



### Learning objectives/experiments

- planning and implementation of a PLC controlled mixing process
- familiarisation with terms and symbols
- presentation of circuits
- functionality test of all sensors and actuators
- sensitivity adjustment of the capacitive proximity switches
- procedure for connecting up the PLC together with PLC module: performance of complex PLC control functions using a complex example from the field of process engineering
- discontinuous metering and mixing

### Description

- **trainer for control of discontinuous mixing processes by PLC**
- **use of standard industrial components**
- **capacitive proximity switches as level sensors**
- **built-in power supply unit to power all the components and the PLC**

This trainer for PLC applications can be used to create complex PLC control functions from the field of process engineering, particularly for processes involving metering and mixing. The system consists of the base frame with a storage tank, a centrifugal pump and a panel on which all components are clearly laid out. A pump delivers water to three tanks, controlled via solenoid valves.

The level of water in the three tanks is monitored by capacitive proximity switches with adjustable sensitivity. The fluid from the three tanks can be mixed together in the downstream mixing tank. The mixing tank is also equipped with three proximity switches. A stirring machine assists the mixing process. All the tanks are transparent, so the conveying and mixing processes are clearly observable.

The trainer features a lab jack panel by which the signals from the capacitive proximity switches can be processed by PLC, and all the solenoid valves can be individually controlled. PLC systems from different manufacturers can be used. A rail on the model's front panel is provided so as to allow for connection of the PLC.

Although a PLC is not included in the package, the operation of the system can be checked without one. We recommend the use of PLC module IA 130.

# RT 800

## PLC application: mixing process

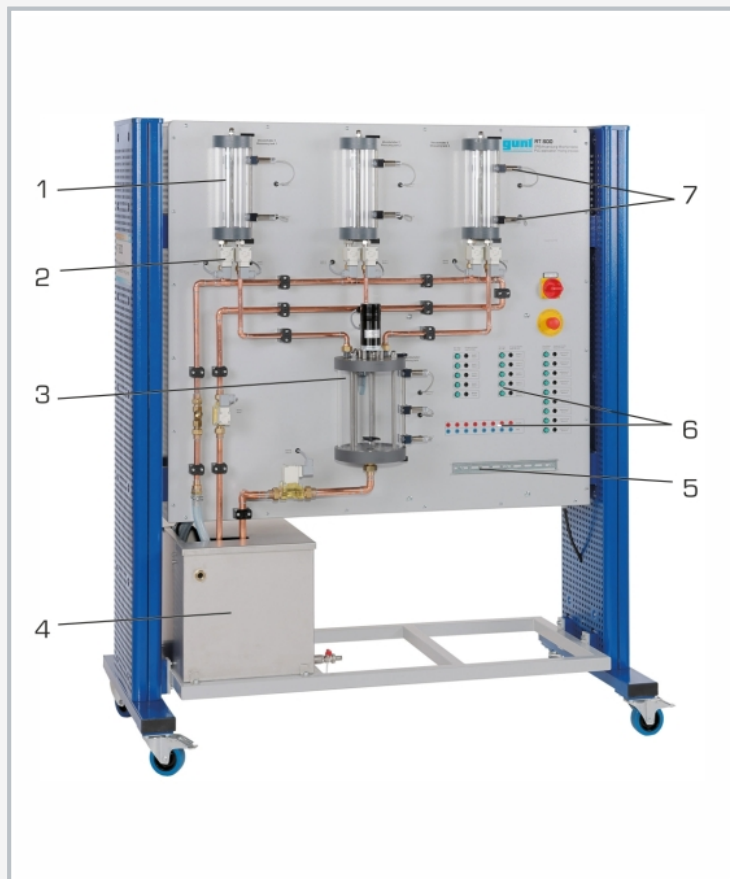

1 measuring tank, 2 solenoid valve, 3 mixing tank with stirring machine, 4 storage tank, 5 rail for mounting of a PLC system, 6 lab jack panel for connection of a PLC, 7 level sensor

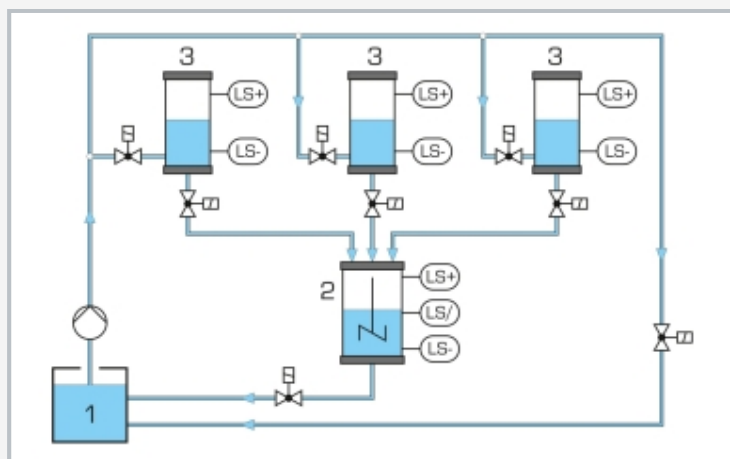

Process schematic: 1 storage tank, 2 mixing tank, 3 measuring tank; LS level sensors (+: high, /: middle, -: low)

### Specification

- [1] clearly laid out trainer as basis for the use of a PLC in a process control application involving mixing processes
- [2] transparent mixing tank with 3 capacitive proximity switches to monitor the level
- [3] 3 transparent measuring tanks, each with 2 capacitive proximity switches
- [4] metering from the 3 measuring tanks into the mixing tank via solenoid valves
- [5] mixing assisted by stirring machine in mixing tank
- [6] proximity switch signals processed by PLC via lab jack panel
- [7] control of the 8 solenoid valves, the pump and the agitator also by PLC via lab jack panel
- [8] capacitive proximity switches with adjustable sensitivity
- [9] closed water circuit with centrifugal pump and stainless steel storage tank
- [10] power supply to all components and to PLC by built-in power supply unit

### Technical data

Centrifugal pump (submersible pump)

- power consumption: 430W
- max. flow rate: 150L/min
- max. head: 7m

Tanks

- storage tank: 70L
- 3 measuring tanks: each 1500mL
- mixing tank: 7L

Capacitive proximity switches, NO contacts

2/2-way solenoid valves 6x DN8, 1x DN20, 1x DN15

Power supply unit: 24VDC, 8A

230V, 50Hz, 1 phase

230V, 60Hz, 1 phase

120V, 60Hz, 1 phase

UL/CSA optional

LxWxH: 1618x792x1903mm

Weight: approx. 223kg

### Scope of delivery

- 1 trainer
- 1 set of instructional material

# RT 800

## PLC application: mixing process

Optional accessories

IA 130

PLC module