

ST 510

Full-scale sewerage system



Description

- transparent pipes and tanks for observation of flow processes
- closed water circuit

The routing of sewers is particularly important in wastewater engineering. Pipe inclinations, pipe inlets and outlet, reducers and cross-sections must be considered when designing systems, taking into account interactions between the components. In particular, the pressure distribution in complex pipe systems places high demands on design engineers. Design errors lead to noise, empty drain traps and clogged pipes.

ST 510 allows a variety of experiments in the field of wastewater engineering and enables the visualisation of flow processes in sewers.

The experimental plant includes an extensive drainage pipe system based on common real-world elements.

The pipes are transparent to allow visualisation of the flow processes. The cisterns are located in the top part of the experimental plant. These are opened or closed individually via solenoid valves. In addition, the bypass, ventilation pipe and pressure flushing are equipped with solenoid valves. The solenoid valves are triggered via a remote control. The system can be used to study the flow and pressure curve at different types of junctions, pipe offsets, cross-sectional changes and drain traps under different ventilation and evacuation conditions. The system contains a closed water circuit with collection tank and pump.

There are pressure measuring points located along the downcomer to measure the pressure conditions in the wastewater system. The measuring points are connected to a tube manometer via hose connections. The flow rate is determined via a rotameter.

Learning objectives/experiments

- pressure curve in the downcomer
- bypass
- incorrect flow behaviour with defective ventilation of the pipes
- incorrect flow behaviour with incorrect pipe sizing
- flow at pipe offset
- suction effect at junctions
- behaviour of sanitary valves and fittings
- function of various drainage pipes

ST 510

Full-scale sewerage system

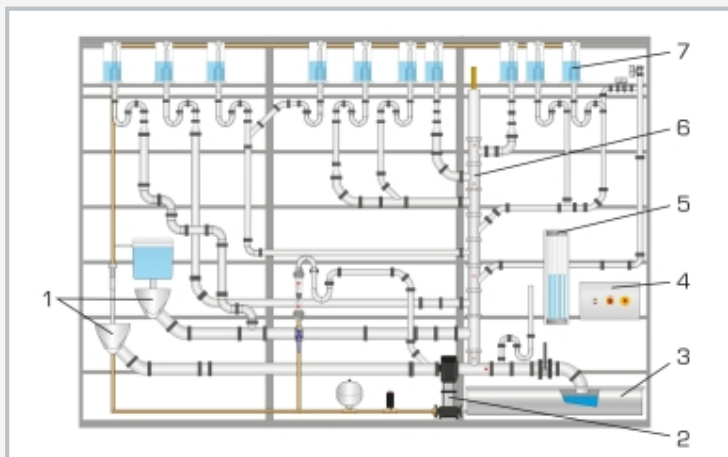

1 toilet bowl, 2 pump, 3 tank, 4 switch cabinet, 5 tube manometer, 6 downcomer with pressure measuring points, 7 cistern



1 toilet bowl pressure flush, 2 toilet bowl with cistern, 3 transparent pipes

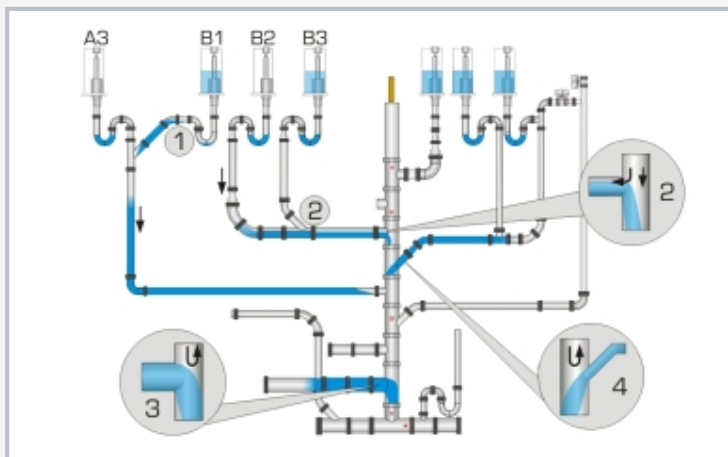

1 incorrect: drain trap B1 emptied through Y-piece when flushing A3, 2 correct: drain trap B3 not emptied by cross-sectional expansion and good ventilation when flushing B2, 3 ventilation failure due to equal pipe cross-sections, 4 ventilation failure due to high flow velocity

Specification

- [1] experimental plant for demonstration of wastewater technology
- [2] transparent glass pipes and tanks
- [3] 10 cisterns with remotely-operated solenoid valves
- [4] 1 toilet with cistern
- [5] 1 toilet with pressure flush
- [6] contains downcomer, collection pipe, ventilation pipe and bypasses
- [7] 6 tube manometers to indicate the pressure curve in the downcomer
- [8] measurement of flow rate via rotameter

Technical data

Pump

- power consumption: 550W
- max. flow rate: 4,5m³/h
- max. head: 42,6m

Collection tank

- volume: approx. 300L

Transparent cisterns

- 4x 20L
- 6x 10L

Cistern

- 1x 9L

Flush for toilet: max. 9L

Measuring ranges

- flow rate: 0,4...4L/h
- pressure: 6x 1500mmWC

230V, 50Hz, 1 phase
 230V, 60Hz, 1 phase
 120V, 60Hz, 1 phase
 UL/CSA optional
 LxWxH: 5700x800x3900mm
 Weight: approx. 1100kg

Required for operation

compressed air connection: 6...10bar

Scope of delivery

- 1 experimental plant
- 1 set of hoses
- 2 remote controls
- 1 set of instructional material