

ET 102

Heat pump



Learning objectives/experiments

- design and operation of an air-to-water heat pump
- representation of the thermodynamic cycle in the log p-h diagram
- energy balances
- determination of important characteristic variables
 - ▶ compressor pressure ratio
 - ▶ ideal coefficient of performance
 - ▶ real coefficient of performance
- dependence of the real coefficient of performance on the temperature difference (air-to-water)
- operating behaviour under load

Description

- utilisation of ambient heat for water heating
- display of all relevant values at the location of measurement
- dynamic recording of the refrigerant mass flow rate

A heat pump usually extracts the energy from the environment. Common energy sources are air, groundwater, ground or river water. An energy source temperature which is as high and constant as possible is the key for high efficiency.

With the air-to-water heat pump ET 102 the ambient heat of the air is used to heat water. The heat pump circuit consists of a compressor, an evaporator with ventilator, a thermostatic expansion valve and a coaxial coil heat exchanger as condenser. All components are clearly arranged in the trainer.

The compressed refrigerant vapour condenses in the outer pipe of the condenser and thereby discharges heat to the water in the inner pipe. The liquid refrigerant evaporates at low pressure in the finned tube evaporator and thereby absorbs heat from the ambient air. The air flow is adjustable via a powerful EC ventilator.

The hot water circuit consists of a tank, a pump and the condenser as heater. For a continuous operation the generated heat is dissipated via an external cooling water connection. The cooling water flow rate is set via a valve and measured.

All relevant measured values are recorded by sensors and displayed. The simultaneous transmission of the measurements to a data recording software enables analysis and the representation of the process in the log p-h diagram. The GUNT software provides exact data on the condition of the refrigerant, which is used to calculate the refrigerant mass flow rate accurately. The calculation therefore gives a much more accurate result than measurement using conventional methods. The software also displays the key characteristic variables of the process, such as the compressor pressure ratio and the coefficient of performance.

ET 102

Heat pump



1 expansion valve, 2 evaporator with ventilator, 3 pressure sensor, 4 pressure switch, 5 displays and controls, 6 compressor, 7 cooling water flow meter, 8 pump, 9 hot water tank, 10 receiver, 11 cocondenser

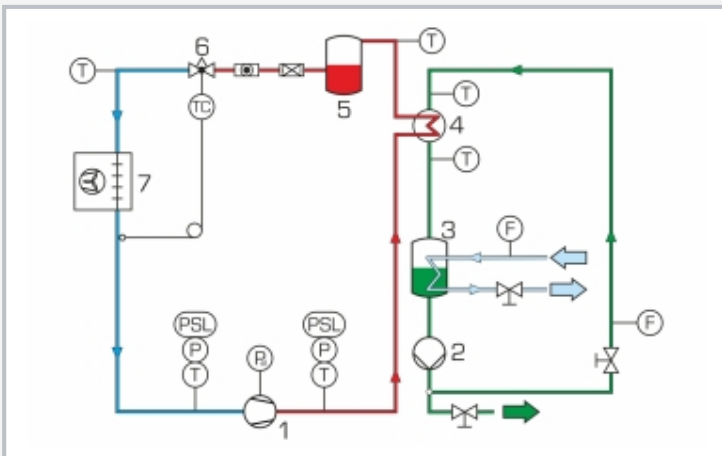

1 compressor, 2 pump, 3 hot water tank with external cooling water connection, 4 condenser, 5 receiver, 6 expansion valve, 7 evaporator with ventilator; T temperature, P pressure, F flow rate, P_{el} power, PSH, PSL pressure switch; blue/red: refrigeration circuit, green: hot water circuit, light blue: cooling water

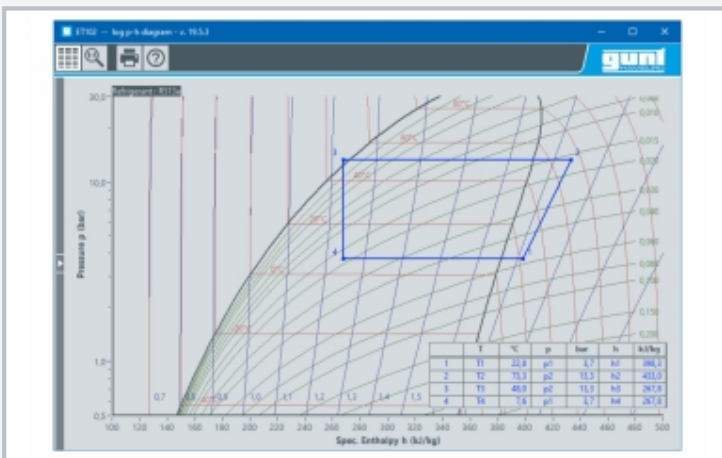

Software screenshot: log p-h diagram

Specification

- [1] investigation of a heat pump with a water circuit as load
- [2] refrigeration circuit with compressor, evaporator with ventilator, thermostatic expansion valve and coaxial coil heat exchanger as condenser
- [3] EC ventilator enables very high load variability
- [4] hot water circuit with pump, tank and condenser as heater
- [5] additional cooling via pipe coil in the hot water tank and external cooling water
- [6] record and display of all relevant measured values
- [7] refrigerant mass flow rate precisely calculated via GUNT software
- [8] GUNT software for data acquisition via USB under Windows 10
- [9] refrigerant R513A, GWP: 631

Technical data

- Compressor
- refrigeration capacity: 372W at 7,2/55°C
 - power consumption: 205W at 7,2/55°C
- Coaxial coil heat exchanger (condenser)
- refrigerant content: 0,55L
 - water content: 0,3L
- Finned tube evaporator
- transfer area: approx. 0,175m²
 - air flow 0...1400m³/h
- Pump
- max. flow rate: 1,9m³/h
 - max. head: 1,4m
- Hot water tank volume: approx. 4,5L

Refrigerant: R513A

- GWP: 631
- filling volume: 1kg
- CO₂-equivalent: 0,6t

Measuring ranges

- pressure: 2x -1...15bar
- temperature: 4x 0...100°C, 2x -100...100°C
- power: 0...6000W
- flow rate:
 - ▶ water 0...108L/h
 - ▶ cooling water 10...160L/h
 - ▶ refrigerant calculated 0...17kg/h

230V, 50Hz, 1 phase; 230V, 60Hz, 1 phase

120V, 60Hz, 1 phase; UL/CSA optional

LxWxH: 1630x800x1900mm

Weight: approx. 195kg

Required for operation

water connection, drain, PC with Windows recommended

Scope of delivery

trainer, GUNT software + USB cable, set of instructional material

ET 102

Heat pump

Optional accessories

for Remote Learning

GU 100

Web Access Box

with

ET 102W

Web Access Software