

# ET 360

## Refrigeration circuit with propane



screen mirroring is possible on up to 10 end devices

### Description

- **log p-h diagram in real time**
- **detailed animations of the main components**
- **Game-Based Learning: learn complex theory easily and playfully**

Due to the high environmental impact of conventional refrigerants, there is interest in the long term in avoiding the use of fluorinated gases and using natural refrigerants instead. One currently promising gas is propane. The gas has very good thermodynamic properties and is available globally.

ET 360 is used to investigate the refrigeration circuit under an adjustable load. The refrigeration circuit consists of a compressor, a condenser with ventilator, a thermostatic expansion valve and a microchannel heat exchanger as evaporator. The evaporator can be operated in a refrigeration chamber or with a permanent flow through.

All relevant measured values are captured by sensors. The simultaneous transfer of the measured values to a PLC enables easy analysis and the representation of the process in the log p-h diagram. Complex processes, such as changes of state, are visualised by real-time representation of the cycle, e.g. in the log p-h diagram.

Intuitive operation of the PLC makes it easy to adjust all elements of the cycle. The effect of the modifications is immediately visible on the touch screen.

The PLC provides accurate data on the condition of the refrigerant, which is used for precise calculation of the refrigerant mass flow. The calculation therefore provides a much more accurate result than measurement with conventional methods.

The experimental unit is controlled by a PLC via touch screen. By means of an integrated router, the experimental unit can alternatively be operated and controlled via an end device. The user interface can also be displayed on additional end devices (screen mirroring). Via the PLC, the measured values can be stored internally.

Digital multimedia teaching material is available at the GUNT Media Center. In addition to real-time representation directly on the unit, Game-Based Learning is made possible with these online media, e.g. worksheets, e-learning, videos, etc.

### Learning objectives/experiments

- represent and understand the refrigeration cycle in the log p-h diagram
- determine main characteristic variables
  - ▶ coefficient of performance
  - ▶ refrigeration capacity
  - ▶ compressor work
- operating behaviour under load: steady and transient load behaviour
- GUNT Media Center, develop digital skills
  - ▶ retrieve information from digital networks
  - ▶ use digital learning media, e. g. Web Based Training (WBT)
  - ▶ use visualisation systems

# ET 360

## Refrigeration circuit with propane

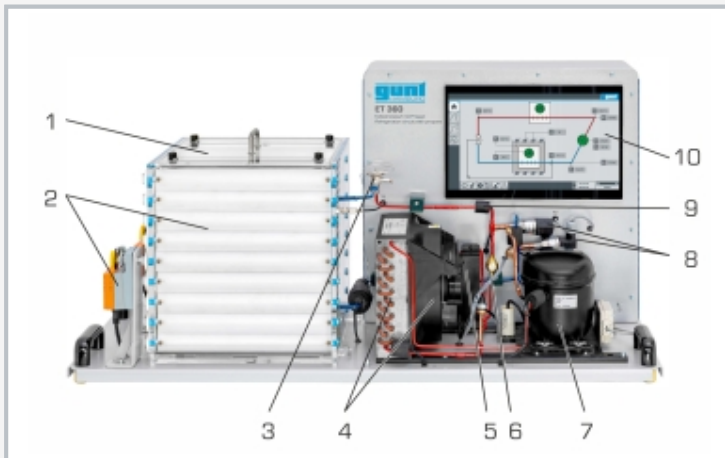

1 refrigeration chamber with evaporator, 2 multileaf dampers and adjusting motor, 3 thermostatic expansion valve (TEV), 4 condenser with ventilator, 5 refrigeration receiver with filter/dryer, 6 sight glass with moisture indicator, 7 compressor, 8 pressure sensor, 9 temperature sensor, 10 touch panel with 15.6" touch screen

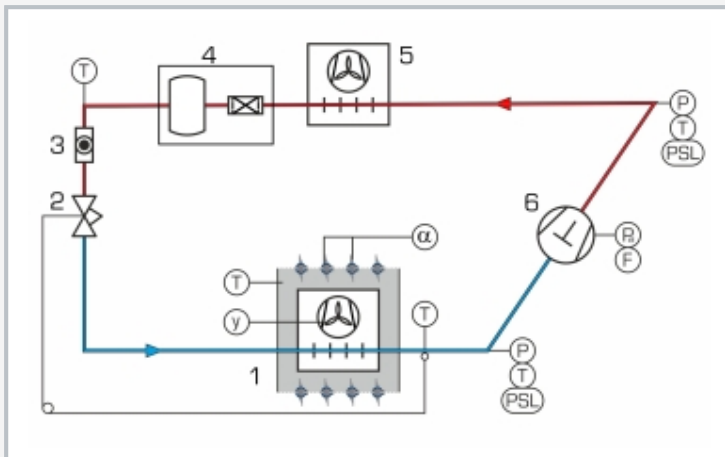

1 refrigeration chamber with evaporator and adjustable multileaf dampers, 3 thermostatic expansion valve (TEV), 4 refrigeration receiver with filter/dryer, 5 condenser with ventilator, 6 compressor; T temperature, P pressure, F refrigerant mass flow, P<sub>el</sub> power consumption, PSH, PSL pressure switch, α adjustment angle multileaf dampers, y manipulating variable ventilator; blue: low pressure, red: high pressure

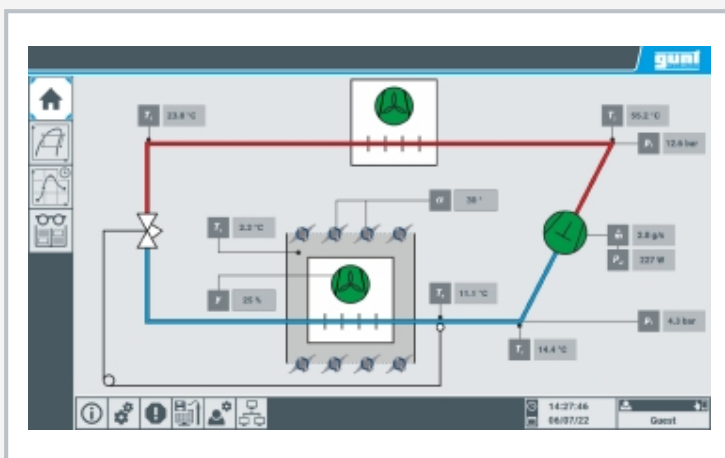

Intuitive user interface provides animations showing how the main components work and displays all measured values in real time

### Specification

- [1] propane refrigeration circuit under adjustable load
- [2] refrigeration circuit: compressor, condenser with ventilator, thermostatic expansion valve, microchannel heat exchanger as evaporator
- [3] transparent refrigeration chamber, adjustable load
- [4] sensors for pressure, temperature, power
- [5] precise calculation of refrigerant mass flow
- [6] 15.6" touch screen with animations showing how the main components work
- [7] representation of all measured values in real time over a time axis, such as the log p-h diagram
- [8] adjust the scale of the axes and the degree of magnification on the touch screen
- [9] control of the experimental plant using a PLC, operated by touch screen
- [10] screen mirroring: possible to mirror the user interface on up to 10 end devices
- [11] data acquisition via PLC on internal USB memory, access to stored measured values via WLAN/LAN with integrated router/LAN connection to customer's own network or direct LAN connection without customer network
- [12] refrigerant R290, GWP: 3
- [13] digital multimedia teaching material online in the GUNT Media Center: E-Learning course, worksheets, videos

### Technical data

PLC: Weintek cMT3162X

Compressor

- displaced volume 5,98cm<sup>3</sup>

- refrigeration capacity: approx. 700W at -10/32°C

- power consumption: approx. 300W at -10/32°C

Ventilator, EC motor

- rated speed: 2330min<sup>-1</sup>

- drive motor power: 83W

- flow rate: 0...1710m<sup>3</sup>/h

Refrigerant: R290, GWP: 3, fill quantity: 150g, CO<sub>2</sub> equivalent: 0t. security: DIN EN 378: A3

Measuring ranges

- pressure: 2x -1...34bar

- temperature: 5x -50...180°C

- power: 0...750W

- mass flow rate: refrigerant, calculated 0...17kg/h

230V, 50Hz, 1 phase; 230V, 60Hz, 1 phase

LxWxH: 1200x520x614mm

Weight: approx. 50kg

### Required for operation

ambient temperature: max. 42°C, min. 10°C

PC with Windows recommended

### Scope of delivery

trainer, online access to the GUNT Media Center, set of instructional material

# **ET 360**

## **Refrigeration circuit with propane**

Optional accessories

WP 300.09      Laboratory trolley