

ET 256

Cooling with solar electricity



Description

- **compression refrigeration system for operation with ET 250 photovoltaic modules or with laboratory power supply ET 256.01**
- **long cooling time due to cold accumulators and insulation**
- **software for controlling and balancing energy flows**
- **dynamic recording of the refrigerant mass flow rate**

With the increasing demand for refrigeration worldwide, the interest in processes of cold production which can be supplied from renewable energy sources is also growing. The use of solar electricity offers particular advantages for mobile and very remote applications.

ET 256 contains a typical compression refrigeration system with refrigeration chamber. It is possible to supply the refrigerant compressor directly with current from photovoltaic modules. To do this, the photovoltaic modules from ET 250 are connected to ET 256. For some experiments, the laboratory power supply ET 256.01 can also be used. The artificial light source HL 313.01 enables solar energy experiments independently of natural sunlight.

The refrigerant compressor is a piston

compressor with adjustable speed. A thermostatic expansion valve is used in the refrigeration circuit. The insulated refrigeration chamber contains a refrigerant evaporator with fan, removable cold accumulator and a heater for generating a cooling load.

For cooling, the compressor is started by the control unit when sufficient electrical power is available from the solar modules. Operating the compressor reduces the temperature in the refrigeration chamber. Should the cold accumulators be fully or partially discharged, they are charged again as soon as sufficiently low temperatures are reached. If there is no current available to operate the compressor, the cold accumulators increase the remaining cooling time in the refrigeration chamber and are discharged in this way.

Relevant measured values are recorded by sensors, displayed and can be processed in a PC. The GUNT software provides exact data on the condition of the refrigerant, which is used to calculate the refrigerant mass flow rate accurately. The calculation therefore gives a much more accurate result than measurement using conventional methods.

Learning objectives/experiments

- supply a compression refrigeration system with current from photovoltaic modules
- components of a photovoltaic refrigerating plant
- operation of the compressor with changing power available and cooling demand
- charge and discharge cold accumulators
- coefficient of performance of the refrigerating plant dependent on operating conditions
- refrigeration cycle in the log p-h diagram
- energy flow balance

ET 256

Cooling with solar electricity

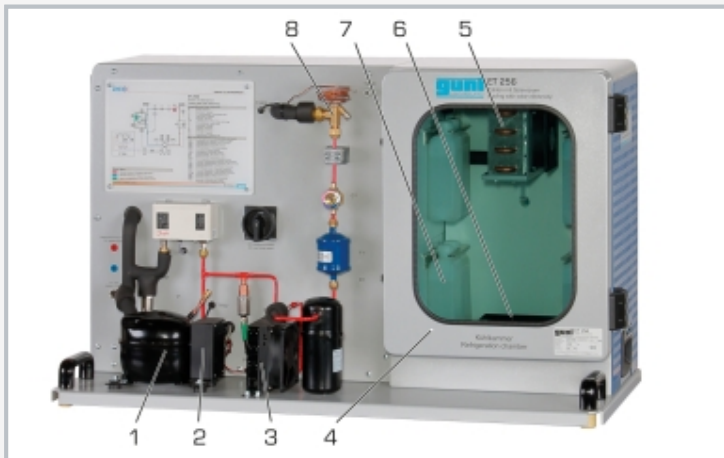

1 compressor, 2 control unit, 3 condenser, 4 refrigeration chamber, 5 evaporator, 6 heater, 7 cold accumulator, 8 expansion valve

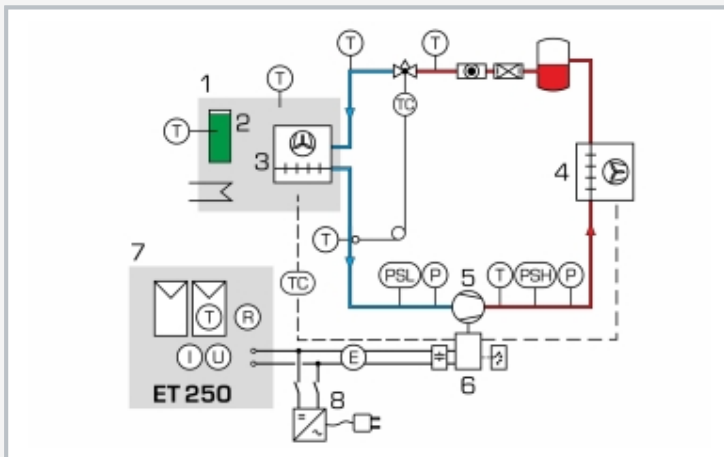

1 refrigeration chamber, 2 cold accumulator, 3 evaporator, 4 condenser, 5 compressor, 6 control unit, 7 photovoltaic modules, 8 laboratory power supply (ET 256.01)



ET 256 together with the optional artificial light source HL 313.01 and solar modules ET 250

Specification

- [1] compression refrigeration system for operation with electricity from ET 250 photovoltaic modules or from laboratory power supply ET 256.01
- [2] compression refrigeration system: refrigerant compressor with adjustable speed, insulated refrigeration chamber with evaporator, cold accumulators and cooling load, thermostatic expansion valve and condenser
- [3] supply with direct current from photovoltaic modules in ET 250
- [4] heater to generate a cooling load
- [5] control unit for temperature-controlled compressor operation
- [6] rechargeable cold accumulators
- [7] sensors to capture temperature and pressure
- [8] refrigerant mass flow rate precisely calculated via GUNT software
- [9] GUNT software with control functions and data acquisition via USB under Windows 10
- [10] refrigerant R513A, GWP: 631

Technical data

Compressor

- speed: 2000...3500min⁻¹
- refrigeration capacity: approx. 90W at 0/55°C and 2000min⁻¹
- electrical power consumption: approx. 46W at 0/55°C and 2000min⁻¹

Control unit: input voltage range: 10...45V DC

Refrigeration chamber: LxWxH: 400x250x580mm

Cold accumulators: phase transition: 5...6°C

Refrigerant

- R513A
- GWP: 631
- filling volume: 450g
- CO₂-equivalent: 0,3t

Measuring ranges

- temperature: 4x -30...80°C, 3x 0...120°C
- pressure: 2x 0...6bar, 2x 0...30bar
- current: 0...10A
- voltage: 0...60V
- flow rate: refrigerant calculated 0...1.1 kg/h

230V, 50Hz, 1 phase

LxWxH: 980x400x580mm

Weight: approx. 65kg

Required for operation

PC with Windows

Scope of delivery

- 1 experimental unit
- 1 set of cables
- 1 GUNT software + USB cable
- 1 set of instructional material

ET 256

Cooling with solar electricity

Required accessories

ET 250 Solar module measurements
or
ET 256.01 Laboratory power supply

Optional accessories

HL 313.01 Artificial light source