

# ET 405

## Heat pump for cooling and heating operation



### Description

- air-to-water heat pump
- heating and cooling operation possible
- high practical relevance by using industrial components from refrigeration
- set different operating modes via solenoid valves, to be selected in the GUNT software

Refrigeration systems and heat pumps only differ in the definition of their use, but can be of the same design. For example, goods can be refrigerated in a supermarket and the store heated with the waste heat. The store can also be cooled with the same system in the summer.

With ET 405 the cooling and heating operation can be investigated. Different operating modes can be set via solenoid valves.

The refrigeration circuit with compressor and condenser (heat exchanger with fan) includes two evaporators with fans (refrigeration stage and freezing stage) and thermostatic expansion valves. The two evaporators can be connected in parallel or in series. For the connection in series the capillary tube serves as expansion element for the refrigeration stage evaporator.

The refrigerant circuit is connected to a glycol-water circuit via a coaxial coil heat exchanger. Via solenoid valves the coaxial coil heat exchanger can be switched as an evaporator or condenser. Thus the glycol-water mixture in the tank can be heated or cooled. In pure cooling operation (without heating function) the heat exchanger with fan as air-cooled condenser dissipates the heat. This heat exchanger can be also switched as an evaporator. The different operating modes can be selected in the GUNT software supplied.

The measured values are transmitted via USB directly to a PC and displayed there. The GUNT software enables easy analysis and the representation of the process. In addition, the GUNT software provides exact data on the condition of the refrigerant, which is used to calculate the refrigerant mass flow rate accurately. The calculation therefore gives a much more accurate result than measurement using conventional methods.

### Learning objectives/experiments

- design, operation and key components of a heat pump or refrigeration system
- representation of the thermodynamic cycle in the log p-h diagram
- comparing different operating modes
- measurement of compressor capacity and heating or cooling capacity in the glycol-water circuit
- determination of
  - ▶ efficiency
  - ▶ coefficient of performance of heat pump and refrigeration system
  - ▶ specific compressor load
  - ▶ compressor pressure ratio
  - ▶ specific cooling capacity
  - ▶ specific refrigeration capacity
- comparing key figures of heat pump and refrigeration system

# ET 405

## Heat pump for cooling and heating operation



1 evaporator, 2 expansion valve, 3 capillary tube, 4 freezing stage evaporator, 5 evaporation pressure controller, 6 compressor, 7 receiver, 8 heat exchanger with fan, 9 pump, 10 tank for glycol-water mixture, 11 flow meter (glycol-water), 12 solenoid valve, 13 coaxial coil heat exchanger

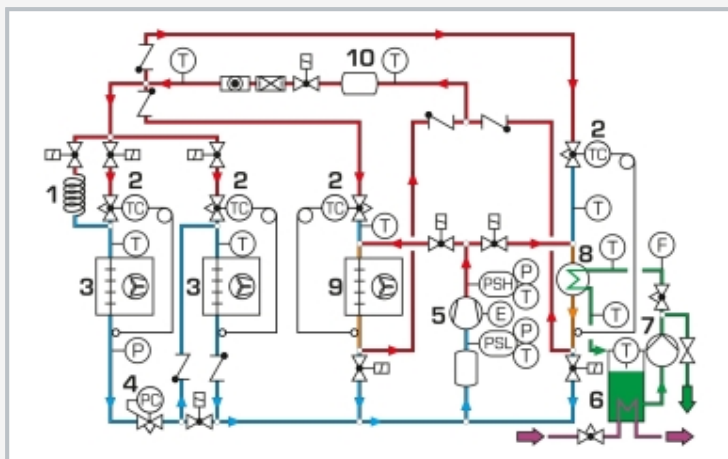

1 capillary tube, 2 expansion valve, 3 evaporator, 4 evaporation pressure controller, 5 compressor, 6 tank for glycol-water mixture, 7 pump, 8 coaxial coil heat exchanger, 9 heat exchanger with fan, 10 receiver; T temperature, P pressure, F flow rate, PSH, PSL pressure switch

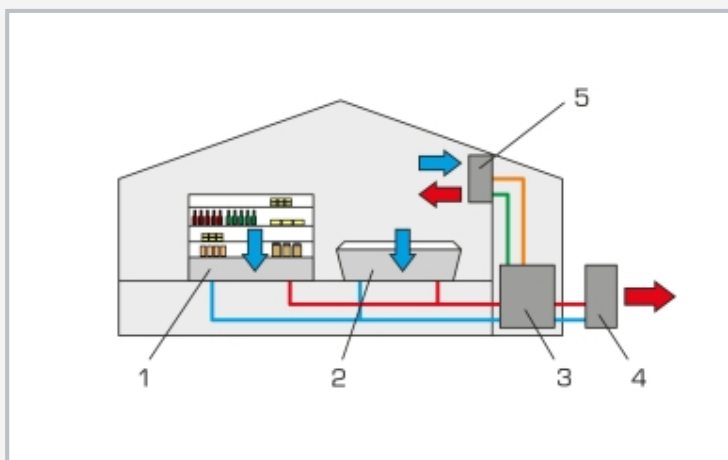

Supermarket application: 1 refrigeration units, 2 freezer, 3 heat pump, 4 external condenser, 5 convactor to heat or cool the sales room

### Specification

- [1] familiarisation with the heat pump or refrigeration system
- [2] set different operating modes via solenoid valves, to be selected in the GUNT software
- [3] refrigeration circuit with compressor, condenser (heat exchanger with fan), 2 evaporators with fan (refrigeration and freezing stage)
- [4] glycol-water circuit with tank, pump and coaxial coil heat exchanger
- [5] coaxial coil heat exchanger and heat exchanger with fan can both be used as condenser or evaporator in the refrigeration circuit
- [6] 1 thermostatic expansion valve each for all heat exchangers and evaporators
- [7] 1 additional evaporation pressure controller and 1 capillary tube for the refrigeration stage evaporator
- [8] display of temperature, pressure, flow rate and power consumption of the compressor in the GUNT software
- [9] refrigerant mass flow rate precisely calculated via GUNT software
- [10] GUNT software for data acquisition via USB under Windows 10

### Technical data

#### Compressor

- refrigeration capacity: 1561W at 5/40°C
- power consumption: 759W at 5/40°C

#### Heat exchanger with fan

- transfer area: 1,25m<sup>2</sup>
- volumetric air flow rate: 650m<sup>3</sup>/h

#### Evaporators with fan

- refrigeration stage transfer area: 1,21m<sup>2</sup>, volumetric air flow rate: 80m<sup>3</sup>/h
- freezing stage transfer area: 3,62m<sup>2</sup>, volumetric air flow rate: 125m<sup>3</sup>/h

#### Refrigerant: R513A, GWP: 631

- filling volume: 1,5kg, CO<sub>2</sub>-equivalent: 0,9t

#### Measuring ranges

- temperature: 11x -50...150°C
- pressure: 2x -1...15bar, 1x -1...24bar
- mass flow rate: refrigerant, calculated 2,5...65g/s
- power: 0...1150W

230V, 50Hz, 1 phase

230V, 60Hz, 1 phase; 120V, 60Hz, 1 phase

UL/CSA optional

LxWxH: 2210x800x1900mm

Weight: approx. 330kg

### Required for operation

water connection, drain, PC with Windows recommended

### Scope of delivery

trainer, set of accessories, GUNT software + USB cable, set of instructional material

# ET 405

## Heat pump for cooling and heating operation

Optional accessories

for Remote Learning  
GU 100            Web Access Box  
with  
ET 405W            Web Access Software