

## CE 283

### Drum cell filter



#### Learning objectives/experiments

- learning the basic principle and method of operation of a drum cell filter
- fundamentals of cake filtration
- variation in time of filtrate quantity, filter cake mass and thickness
- filter cake mass and thickness dependent on filtrate quantity, negative pressure and drum speed

#### Description

- separation of solids from suspensions
- continuous removal of filter cake
- practical experiments on a laboratory scale

Drum cell filters can be used to separate solids continuously from suspensions.

The suspension unit produces a suspension of diatomite and water. A pump conveys the suspension into the suspension tank of the drum cell filter. A stirrer keeps the solid particles in the suspension suspended. Part of the rotating drum dips into the suspension. The jacket of the drum is perforated and covered over with a filter cloth. The drum is divided into cells. Each cell is joined by a hollow shaft to a vacuum line.

The vacuum sucks filtrate through the filter cloth into the drum. From there it is carried in a collector tank which is under vacuum. The solid is separated off at the filter cloth. Consequently, a filter cake which steadily grows in the direction of rotation is created on the immersed part of the drum.

When the filter cake is drawn out of the suspension by the rotating motion, it is drained of water by the applied vacuum. A scraper scrapes the filter cake off of the drum before the drum dips back into the suspension. Compressed air can also be used to remove the filter cake. The filter cake drops into a collector tank.

The flow rate of the supplied suspension is adjusted on the suspension unit. The level in the suspension tank of the drum cell filter can be adjusted by way of an adjustable overflow. The applied negative pressure is indicated by a manometer on the vacuum tank. The rotation speed of the drum is infinitely variable.

Compressed air and vacuum connections are required to operate the trainer.

# CE 283

## Drum cell filter



1 filter cake collector tank, 2 balance, 3 suspension storage tank, 4 filtrate vacuum tank, 5 overflow/outlet, 6 drum cell filter, 7 vacuum supply, 8 stirrer

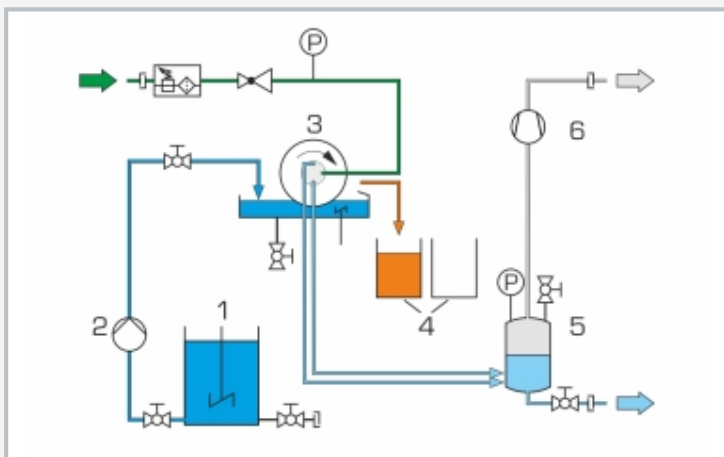

1 suspension storage tank, 2 suspension pump, 3 drum cell filter, 4 filter cake collector tank, 5 filtrate vacuum tank, 6 air suction fan; P pressure; light blue: filtrate, dark blue: suspension, orange: filter cake, grey: vacuum, green: compressed air

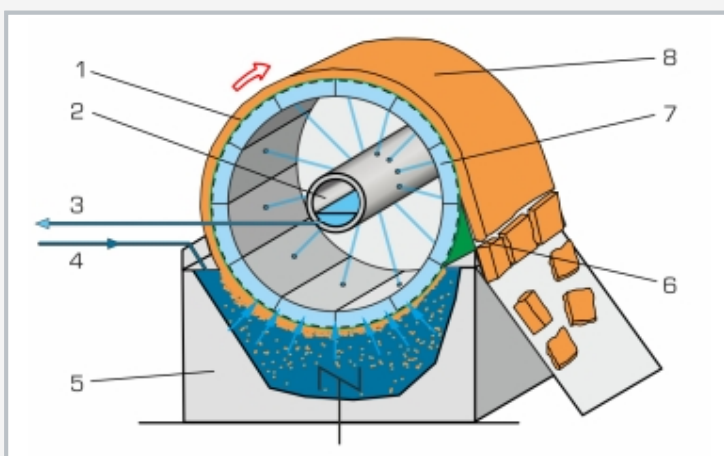

Fundamental principle of a drum cell filter: 1 perforated drum with filter cloth, 2 hollow shaft, 3 vacuum (filtrate), 4 suspension inlet, 5 suspension tank, 6 filter cake removal, 7 cell, 8 filter cake

### Specification

- [1] continuous cake filtration of suspensions with a drum cell filter
- [2] rotating perforated drum, partially immersed in suspension, with filter cloth
- [3] vacuum inside drum to draw off filtrate and dry filter cake
- [4] continuous removal of filter cake with adjustable scraper or compressed air
- [5] drum speed infinitely variable
- [6] plastic vacuum tank to collect filtrate
- [7] suspension tank with swing stirrer and overflow
- [8] plastic collector tank for filter cake
- [9] production and transport of suspension with integrated suspension unit
- [10] peristaltic pump as suspension pump

### Technical data

#### Drum cell filter

- filter area: approx. 0,1m<sup>2</sup>
- speed: approx. 0,1...2min<sup>-1</sup>
- motor power consumption: approx. 200W

#### Swing stirrer

- speed: approx. 15min<sup>-1</sup>
- motor power consumption: approx. 200W

#### Suspension pump

- max. flow rate: 160L/h
- max. pressure: 6bar

#### Tanks

- filtrate vacuum tank: approx. 30L
- 2 filter cake collector tanks: approx. 30L
- suspension tank: approx. 5,5L, max. 10bar
- suspension storage tank: approx. 200L

#### Stirrer at suspension storage tank

- speed: approx. 600min<sup>-1</sup>
- power consumption: approx. 40W

#### Measuring ranges

- pressure: 0...1bar (compressed air)
- vacuum: -1...0bar

230V, 50Hz, 1 phase

230V, 60Hz, 1 phase; 120V, 60Hz, 1 phase

UL/CSA optional

LxWxH: 2180x790x1900mm

Weight: approx. 285g

### Required for operation

water connection, drain

compressed air: 3000L/h, min. 0,3bar

### Scope of delivery

- 1 trainer
- 1 set of accessories
- 1 set of instructional material