

CE 640

Biotechnological production of ethanol



screen mirroring is possible on different end devices

Description

- practical process for production of ethanol from starch-based biological raw materials
- plant control using a PLC via touch screen
- integrated router for operation and control via an end device and for screen mirroring on additional end devices: PC, tablet, smartphone

As well as its great importance for the chemical and foodstuffs industries, ethanol (alcohol) is increasingly used as a fuel. The CE 640 can be used to conduct realistic experiments for the production of ethanol from starch-based raw materials such as potatoes. The experimental plant consists of three main components: a mash tank, a fermentation tank and a distillation unit.

A mixture of water, finely chopped potatoes and alpha-amylase (enzyme) is filled into the mash tank. To dissolve the tightly packed starch chains in the potatoes, heating steam is injected into the mixture via a nozzle (gelatinisation). This increases the flow resistance of the mash, which would prevent further processes. The alpha-amylase breaks up the starch chains (liquefying) thereby reducing the flow resistance. Gluco-amylase is used to convert the starch into sugar (saccharification). This enzyme requires lower temperatures and pH values. The temperature is reduced using the water cooling jacket

around the mash tank, the pH value is adjusted by the addition of acid and caustic. After saccharification the mash is pumped into the fermentation tank. During the fermentation process in this tank, ethanol is produced. A water cooling system controls the temperature. After the fermentation process, the mash is pumped into the distillation unit. This is equipped with a bubble cap tray column for separation of the ethanol. Two tanks are available, one for the spent mash, the other for the distilled ethanol.

The experimental plant has comprehensive measurement, control and operating functions, which are controlled by a PLC via touch screen. By means of an integrated router, the system can alternatively be operated and controlled via an end device. The user interface can also be displayed on additional end devices (screen mirroring). Via the PLC, the measured values can be stored internally. Access to stored measured values is possible from end devices via WLAN with integrated router/LAN connection to the customer's own network.

The steam supply occurs via laboratory network or an optionally available electrical steam generator (CE 715.01).

Learning objectives/experiments

- familiarization with the necessary individual steps and system components for production of ethanol:
 - ▶ gelatinisation by steam injection
 - ▶ liquefaction by use of alpha-amylase
 - ▶ saccharification by use of gluco-amylase
 - ▶ fermentation: conversion of sugar into ethanol by yeast cultures under anaerobic conditions
 - ▶ distillation: separation of ethanol from the mash
- screen mirroring: mirroring of the user interface on end devices
 - ▶ menu navigation independent of the user interface shown on the touch screen
 - ▶ different user levels available on the end device: for observing the experiments or for operation and control

CE 640

Biotechnological production of ethanol

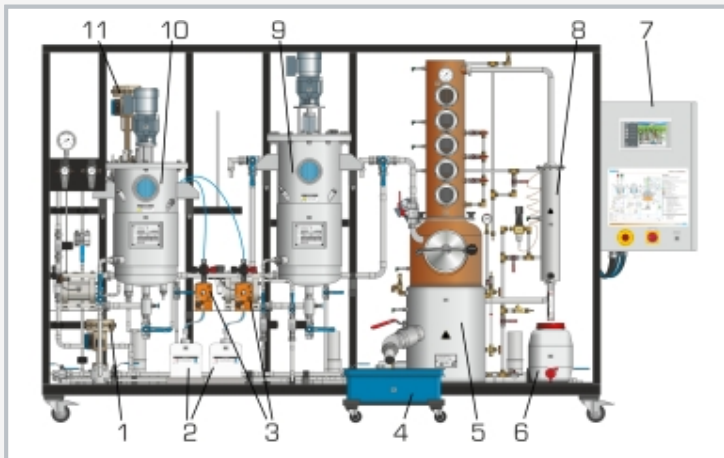

1 cooling water control valve, 2 acid/caustic tanks, 3 acid/caustic pumps, 4 spent mash tank (mobile), 5 distillation unit, 6 product tank, 7 switch cabinet, 8 condenser, 9 fermentation tank, 10 mash tank, 11 steam pressure control valve

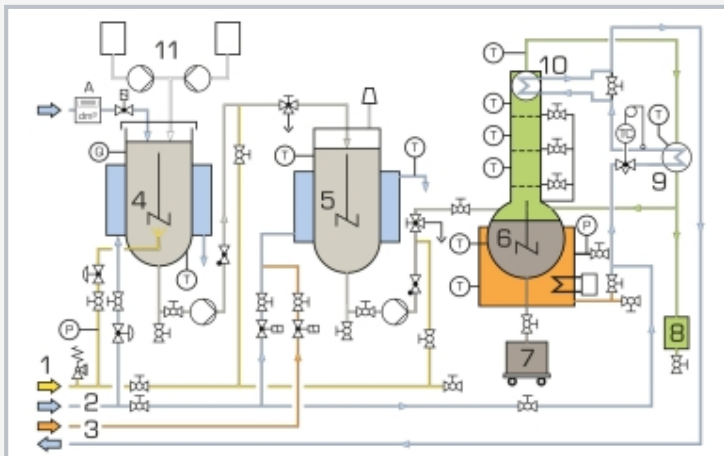

1 heating steam, 2 cooling water, 3 heating water, 4 mash tank, 5 fermentation tank, 6 distillation unit, 7 spent mash tank, 8 product tank, 9 condenser, 10 dephlegmator, 11 acid/caustic pumps and tanks; P pressure, T temperature, A water quantity, Q pH value

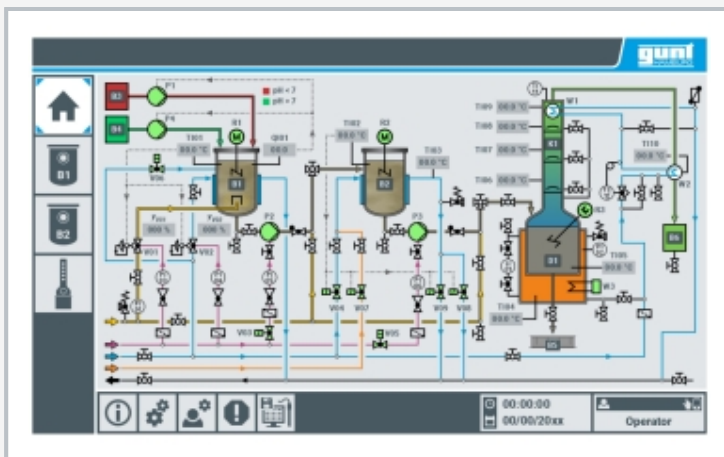

Screenshot of the touch screen for the PLC control unit

Specification

- [1] batch conversion of starch-based raw materials into ethanol
- [2] open mash tank with water-jacket cooling, steam injection and stirrer
- [3] closed fermentation tank with stirrer and water-jacket cooling/heating
- [4] distillation unit with 3 bubble cap trays, dephlegmator, condenser and stirrer
- [5] 2 pumps for delivering the mash
- [6] pH value control in the mash tank with acid and caustic delivered by metering pumps
- [7] adjustment of the amount of injected heating steam, the cooling water flow rates and the head temperature by means of PID controllers
- [8] plant control using a PLC; operated by touch screen
- [9] integrated router for operation and control via an end device and for screen mirroring: mirroring of the user interface on up to 5 end devices
- [10] data acquisition via PLC on internal memory, access to stored measured values via WLAN/LAN with integrated router/LAN connection to customer's own network or direct LAN connection without customer network

Technical data

PLC: Eaton XV303

Mash tank: 40L

Fermentation tank: 50L

Product tank: 10L

Spent mash: 30L

Distillation unit

- column: DxH: 220x1200mm

- sump capacity: 45L

- sump heater: 0...7500W

2 air-operated diaphragm pumps, drive pressure: 2bar

- max. flow rate: 15L/min

- max. head: 20m

- max. solid lump size: 4mm

2 metering pumps (acid and caustic)

- max. flow rate: each 2,1L/h

Measuring ranges

- temperature: 10x 0...150°C

- flow rate: 0...25L/min (to mash tank)

- pH value: 2...10

- pressure: 0...10bar (steam)

400V, 50Hz, 3 phases; 400V, 60Hz, 3 phases

230V, 60Hz, 3 phases; UL/CSA optional

LxWxH: 3500x1200x2000mm; Weight: approx. 500kg

Required for operation

compressed air (1,5...6bar), cold and hot water connection (min. 400L/h, 40°C), drain, CE 715.01 or steam (10kg/h, min. 3bar)

Scope of delivery

experimental plant, 1 set of enzymes etc., 1 set of accessories, 1 set of instructional material

CE 640

Biotechnical production of ethanol

Optional accessories

CE 715.01 Electrical steam generator 12kW