

# HM 164

## Open channel and closed channel flow



### Description

- flow processes in the open channel: gate, sill and various weirs
- flow processes in the closed channel: pipe flow
- closed water circuit with tank and pump

HM 164 is used to demonstrate different flow processes at different control structures in the open channel. In the closed channel, pressure components in a pipe are determined.

The trainer includes a transparent experimental flume with upper limit, a height-adjustable sill and a closed water circuit. The water level in the experimental section is set with an adjustable plate weir at the water outlet. With a simple alteration, the experimental flume can be used as an open or closed channel.

The water level must be low when investigating the open-channel flow. To conduct the experiment, a weir is attached to the bottom of the channel or the height-adjustable sill is used. Furthermore, the discharge under a gate can also be demonstrated. Various weirs, which can be exchanged quickly and safely, are available as control structures.

When studying the closed channel, the water level needs to be high enough that the entire experimental section is flowed through. In this case the sill is used to change the cross-section flowed through.

The static pressures and the total pressure over the cross-section are detected by measuring tubes. The pressure difference is used to calculate the flow velocity.

### Learning objectives/experiments

- open channel
  - ▶ flow over control structures: broad-crested weir, narrow-crested weir, ogee-crested weir with ski jump spillway, sill
  - ▶ discharge under a gate
  - ▶ hydraulic jump
- closed channel
  - ▶ pipe flow with constant and variable flow cross-section
  - ▶ measurement of static pressure and total pressure
  - ▶ calculation of the flow velocity

# HM 164

## Open channel and closed channel flow

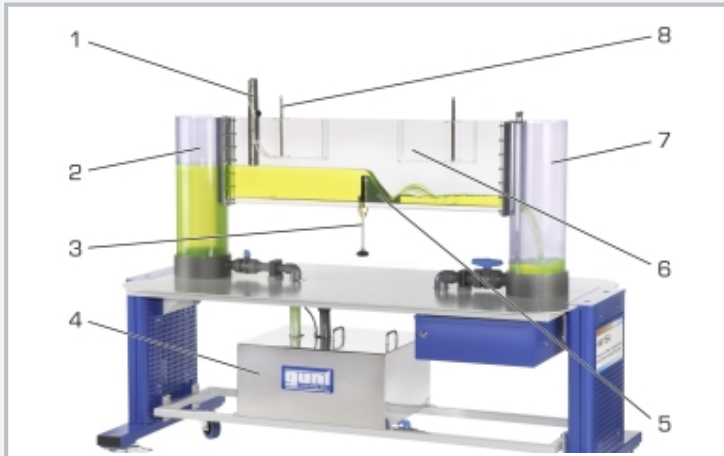

1 sluice gate, 2 water supply, 3 sill height adjustment, 4 supply tank, 5 ogee-crested weir used in the experimental flume, 6 upper limit, 7 water drain with plate weir at the water outlet, 8 measuring tube

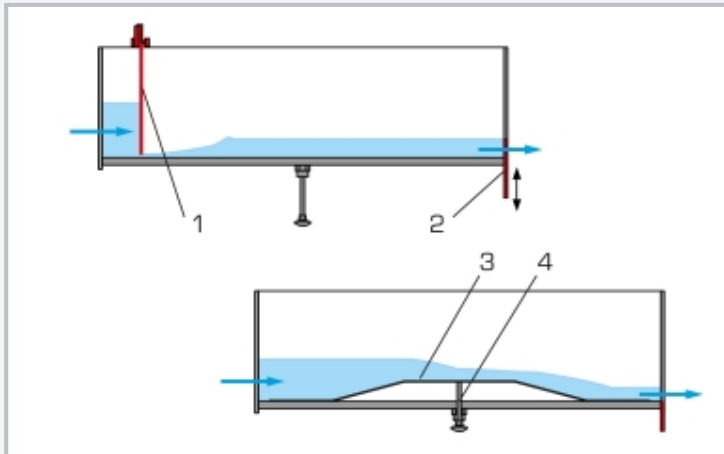

Flow processes in the open channel; 1 flow under a gate, 2 plate weir at the water outlet, 3 flow over a sill, 4 height adjustment of the sill

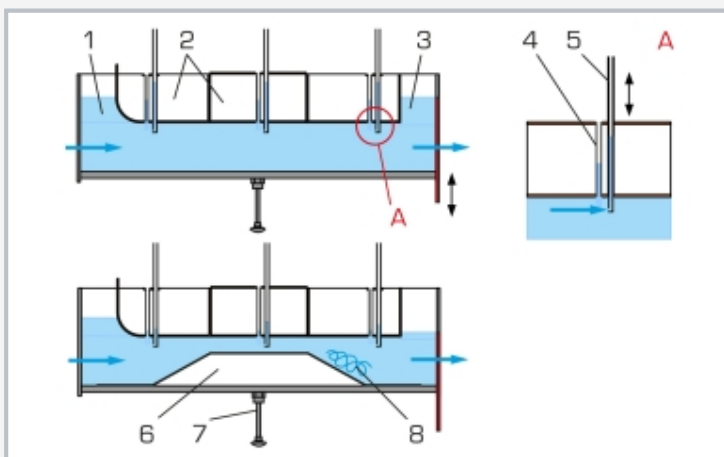

Flow processes in the closed channel; 1 inlet, 2 upper limit, 3 outlet, 4 static pressure measurement, 5 total pressure measurement, 6 sill, 7 height adjustment of the sill, 8 turbulence

### Specification

- [1] investigation of flow processes in the open and closed channel
- [2] experimental flume with upper limit, made of transparent material
- [3] height-adjustable sill in the bottom of the experimental flume
- [4] water level adjustable via plate weir at the water outlet
- [5] simple conversion from open to closed channel
- [6] control structures for experiments in the open channel: broad-crested weir, narrow-crested weir, ogee-crested weir with ski jump spillway, sill, gate fully flowed through experimental section and change in cross-section over sill for experiments in the closed channel
- [7] closed water circuit with supply tank and pump
- [8] transparent measuring tubes for measuring static pressure and total pressure

### Technical data

#### Experimental section

- length: 1,1m
- cross-section WxH: 40x300mm

#### Supply tank: 70L

#### Pump

- power consumption: 250W
- max. flow rate: 150L/min
- max. head: 7,6m

230V, 50Hz, 1 phase

230V, 60Hz, 1 phase; 120V, 60Hz, 1 phase

UL/CSA optional

LxWxH: 1900x800x1350mm

Empty weight: approx. 150kg

### Scope of delivery

- 1 trainer
- 1 set of control structures
- 1 plate weir
- 1 set of tools
- 1 set of instructional material