

HM 220

Air flow experimental plant



Description

- extensive set of matching accessories offers a wide range of experiments
- investigation of flow and pressure curves
- comparison of different ways to measure the volumetric flow rate
- representation of system characteristics and velocity profiles

Fluid mechanics is concerned with the physical behaviour of fluids. An important branch of fluid mechanics is the analysis of air flow in the incompressible range in order to be able to determine the pressure distribution and the velocity profile of a flow. In practice, the findings from these experiments are necessary when devising and designing turbomachines.

With its extensive range of accessories, the HM 220 unit offers a variety of experiments in the field of steady, incompressible flow. The external Pitot tube is used to measure free jets; the inner Pitot tube allows investigation of the air flow within the pipe section. A low-loss inlet and the length of the pipe section realize an optimal formation of the air flow. The air flow can optionally be studied via a nozzle or orifice plate. An iris diaphragm allows the diameter of the air flow to be varied. Pipe friction losses on

various pipe fittings can be investigated. Up to 20 pressure measuring points mean the pressure conditions along the measuring section can be determined. The pressures that are read off the tube manometer make it possible to determine the pressure distribution and flow velocity.

In addition to the extensive accessories supplied, there is the optional Venturi tube HM 220.01 for practical verification of the continuity equation and the conservation of energy during a change in cross-section of the air jet.

As an additional optional accessory, HM 220.02 offers boundary layer measurements on a flat surface in longitudinal flow. The experiment results are used to determine velocity distributions within the boundary layer and to represent the boundary layer thickness.

Learning objectives/experiments

- experiments in the field of steady, incompressible flows by means of different measuring objects:
 - ▶ calculation of the flow rate and the flow velocity
 - ▶ recording the different velocity profiles in both the free jet and the pipe cross-section
 - ▶ representation of the pressure loss in the system characteristic
 - ▶ representation of the pressure loss at different pipe elements

HM 220

Air flow experimental plant

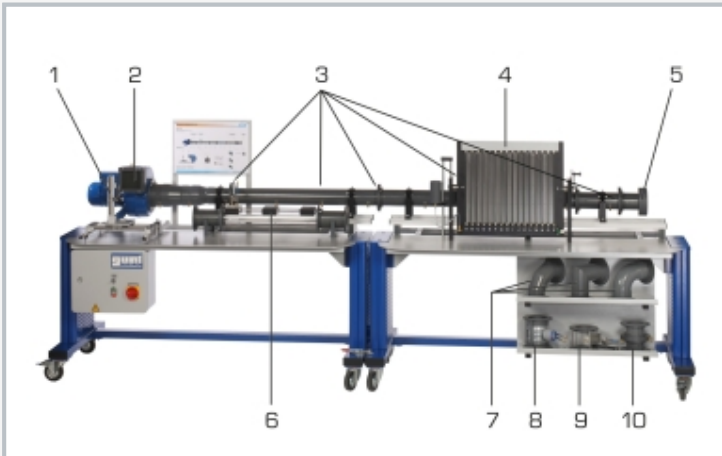

1 Pitot tube (free jet measurement), 2 radial fan, 3 different positions for measuring objects (6, 8-10), 4 tube manometer, 5 inlet, 6 accessory HM 220.02, 7 pipe fittings, 8 iris diaphragm, 9 Pitot tube (internal), 10 nozzle/orifice plate

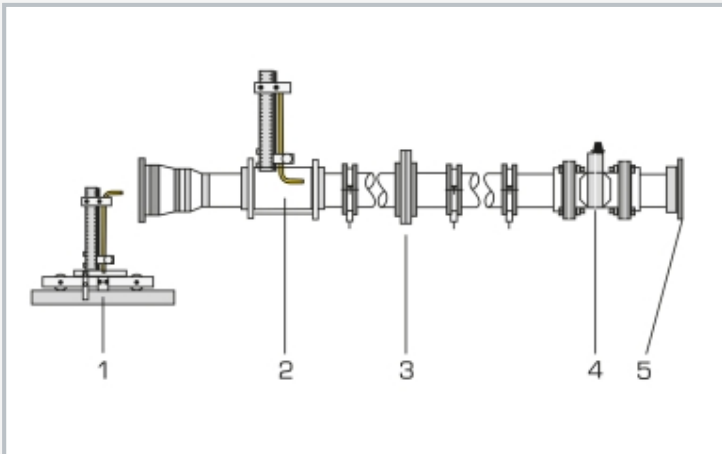

1 Pitot tube (free jet measurement), 2 Pitot tube (within the pipe section), 3 nozzle/orifice plate, 4 iris diaphragm, 5 connection of pipe fittings and the low loss air inlet

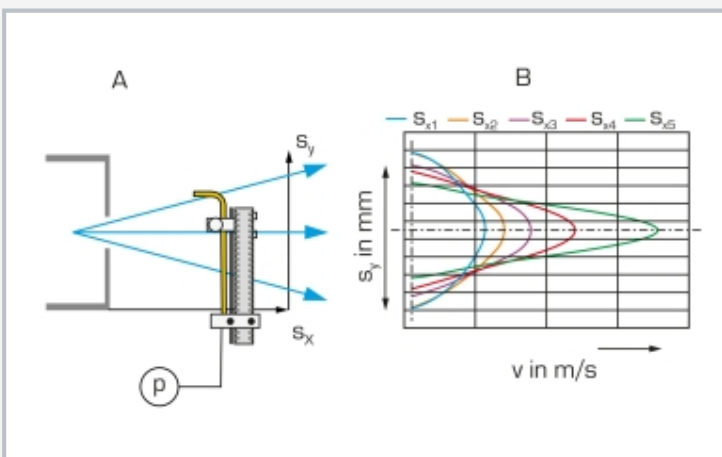

Velocity profile of the free jet
 A measuring principle with schematic representation of the flow course,
 B velocity profile in the air outlet jet;
 v velocity, s_x vertical distance, s_y horizontal distance of the Pitot tube

Specification

- [1] experiments from the field of steady incompressible flow
- [2] horizontal measuring section
- [3] radial fan infinitely variable via frequency converter
- [4] Pitot tube in the free jet, 3-dimensional adjustable
- [5] Pitot tube within the pipe section, vertically adjustable at 3 positions, adjustable height
- [6] different measuring objects: orifice plate, nozzle, iris diaphragm, pipe fittings
- [7] 16 tube manometers for displaying the pressures

Technical data

External Pitot tube in the free jet, 3-dimensional adjustable

- horizontal: $\pm 140\text{mm}$
- vertical: $-80\dots 120\text{mm}$
- inner \varnothing : 2mm

Internal Pitot tube, sliding

- vertical: $\pm 40\text{mm}$
- inner \varnothing : 1,1mm

20 pressure measuring points

Radial fan

- max. motor power: 550W
- max. flow rate: $22\text{m}^3/\text{min}$
- max. differential pressure: 0,73kPa

16 tube manometers

- resolution: 1-fold, 2-fold, 5-fold and 10-fold
- max. resolution: 1Pa

Iris diaphragm: $\varnothing 40\dots 75\text{mm}$

Orifice plate/nozzle: $\varnothing 50\text{mm}$

3 pipe fittings

230V, 50Hz, 1 phase

230V, 60Hz, 1 phase

120V, 60Hz, 1 phase

UL/CSA optional

LxWxH: 3270x790x1130mm

Weight: approx. 232kg

Scope of delivery

- 1 experimental plant
- 1 set of measuring objects
- 1 tube manometer
- 1 set of hoses
- 1 set of tools
- 1 set of instructional material

HM 220

Air flow experimental plant

Optional accessories

HM 220.01	Venturi tube
HM 220.02	Measurement of boundary layers