

HM 220.02

Measurement of boundary layers

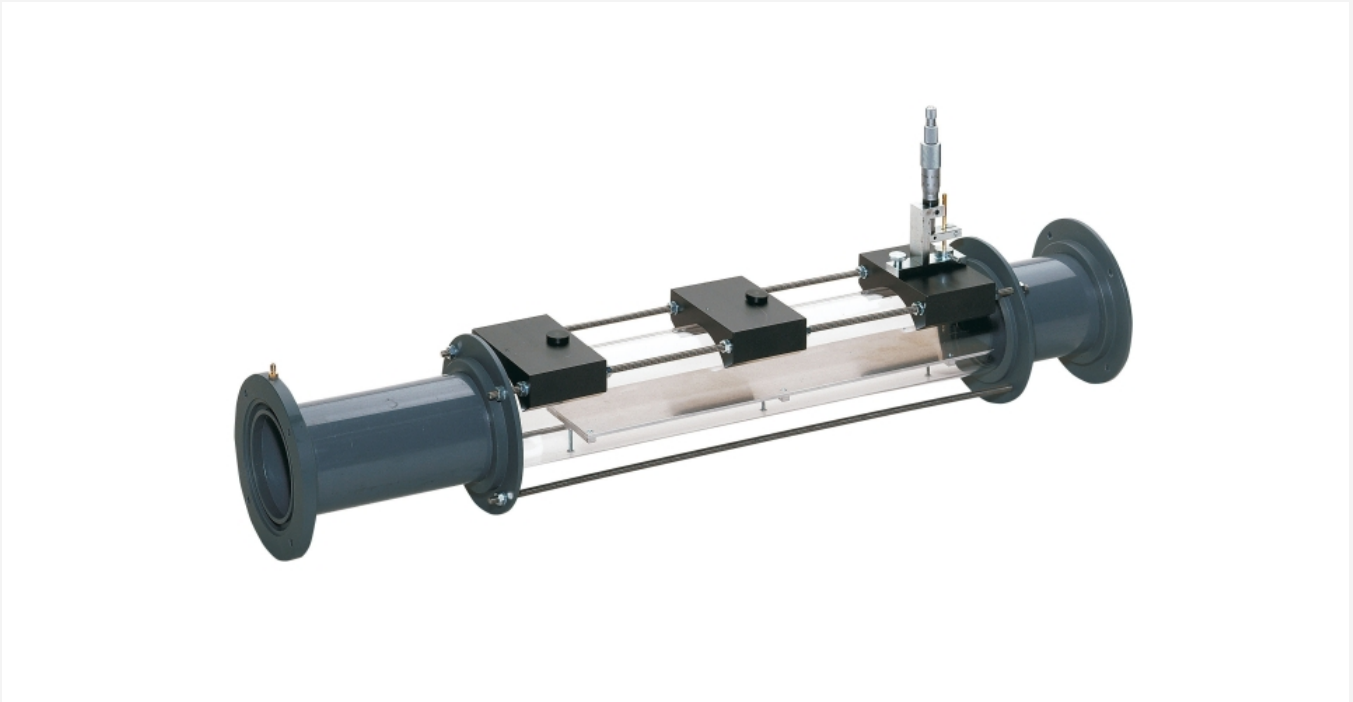

Description

- accessory for experimental plant HM 220
- boundary layer measurements on a flat plate in incident flow

The boundary layer is formed along a surface of a body in incident flow due to the adhesion of the flowing fluid, e.g. air. Internal friction in the fluid causes a change in the flow course and affects flow resistance and flow velocity. Investigations of the boundary layer provide insights that can be applied to aircraft construction or shipbuilding.

By using the experimental unit HM 220.02 in the experimental plant HM 220 it is possible to measure and study boundary layers in flows.

The flat plate is attached in the transparent pipe and subjected to longitudinal flow. In order to minimise turbulence, the leading edge of the plate is fitted with a chamfer. A vertically sliding Pitot tube is used to measure the total pressure. The total pressures can be measured at different distances to the plate surface so that the development of the boundary layer in the flow direction can be detected. An additional measuring point measures the static pressure. Both measuring points are connected to the tube manometer in HM 220. The difference of total and static pressure results in the dynamic pressure from which the velocity is calculated.

Learning objectives/experiments

- investigation of the boundary layer on a flat plate
- representation of velocity profiles

HM 220.02

Measurement of boundary layers

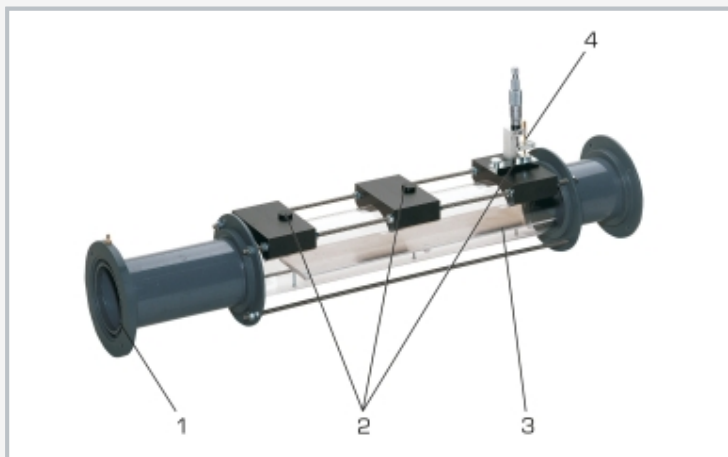

1 connection to experimental plant HM 220, 2 three horizontal positions for the Pitot tube, 3 Pitot tube with micrometre screw for vertical adjustment, 4 flat plate

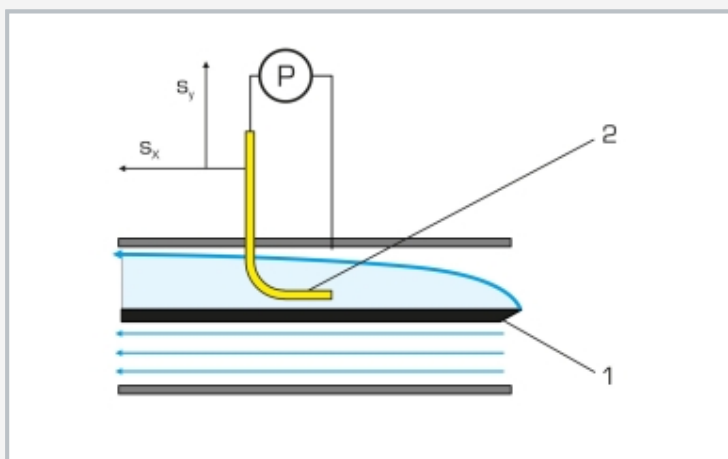

1 plate in longitudinal flow, 2 Pitot tube; P pressure, blue: air flow, s_y distance from the plate surface, s_x distance from the leading edge of the plate

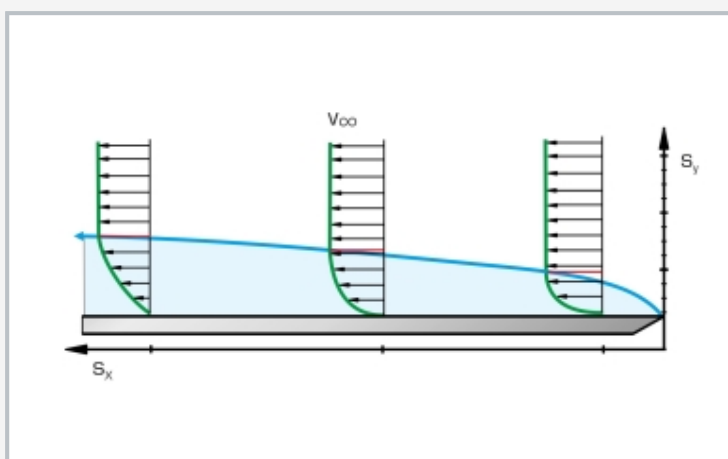

Velocity distribution and boundary layer thickness within the boundary layer of a flat plate in longitudinal flow
 s_y distance from the plate surface, s_x distance from the leading edge of the plate,
 green: velocity profile of the air flow, blue: boundary layer thickness

Specification

- [1] investigation of the boundary layer on a flat plate
- [2] plate leading edge with chamfer
- [3] Pitot tube for measuring the total pressure
- [4] additional measuring point for measuring the static pressure
- [5] vertically sliding Pitot tube can be set to 3 positions along the plate in the measuring section
- [6] display of static and total pressure on the tube manometer from HM 220
- [7] accessory for experimental plant HM 220

Technical data

Pitot tube

- inner diameter: 0,6mm
- vertically sliding: \varnothing ...18mm
- measuring section with 3 positions along the plate:
10mm, 210mm and 410mm from the leading edge

Flat plate

- LxWxH: 420x80x8mm
- 15° chamfer facing the incident flow

LxWxH: 810x160x280mm

Weight: approx. 5kg

Scope of delivery

- 1 experimental unit
- 1 set of tools
- 1 set of instructional material

HM 220.02

Measurement of boundary layers

Required accessories

HM 220 Air flow experimental plant