

HM 299

Comparison of positive displacement machines and turbomachines



Description

- investigation of different driven machines: pumps and compressor
- experiments with liquid or gaseous media

Driven machines release absorbed mechanical work to a liquid or gaseous medium. They are divided into positive displacement machines and turbomachine according to their function. For large volumetric flow rates the benefits of turbomachines are predominant, such as centrifugal pumps; for small volumetric flow rates piston engines are more likely to be used.

The HM 299 trainer allows the comparison of different machines for liquid and gaseous media. One turbomachine and three different positive displacement machines are supplied. Software for data acquisition and visualisation makes the experiments especially clear and enables fast execution of experiments with reliable results.

HM 299 includes a drive motor with speed adjustment, belt drive and protective hood, two pressure vessels for experiments with the compressor and two water tanks for experiments with pumps. Each machine is mounted on a plate and can easily be placed in the trainer. The machines are driven by a belt drive. The pumps are connected to a closed water circuit via hoses with quick-release couplings. Sensors measure the pressures at inlet and outlet, temperature, engine speed and engine output. The respective flow rate is measured indirectly via fill level (water) or Venturi nozzle (air).

The measured values are read from digital displays and can at the same time be transmitted via USB directly to a PC where they can be analysed using the software included.

Learning objectives/experiments

- different pumps and a compressor
- identifying characteristic data
- recording pump, compressor and system characteristics
- representation of operating points in series and parallel configuration of centrifugal pumps
- comparison of the different delivery properties

HM 299

Comparison of positive displacement machines and turbomachines



1 measuring tank, 2 displays and controls, 3 stabilisation and pressure vessel, 4 supply tank, 5 pumps and compressor, 6 drive motor

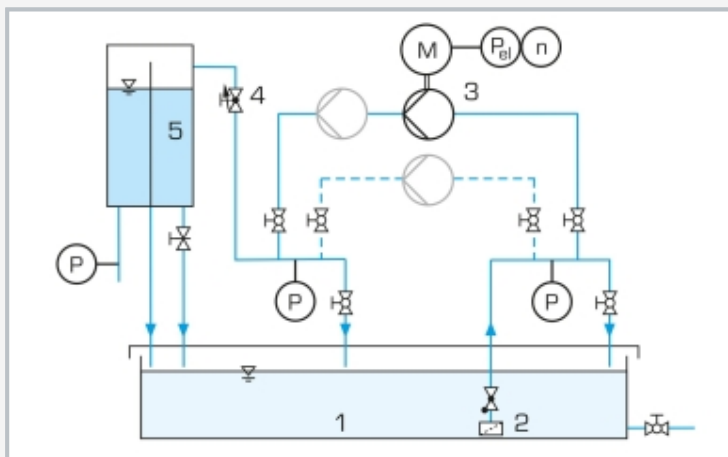

Experiments (centrifugal pumps): 1 supply tank, 2 strainer, 3 pump with drive motor, 4 valve for adjusting the flow rate, 5 measuring tank; P pressure, n speed, P_{el} power

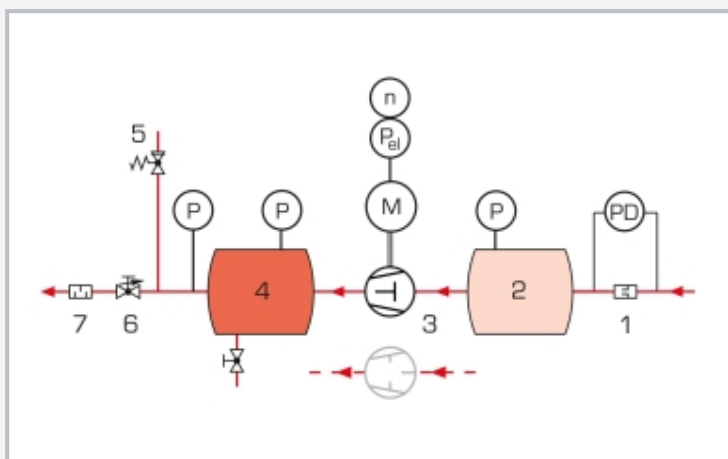

Experiments (compressor): 1 Venturi nozzle for flow measurement, 2 stabilisation tank, 3 compressor with drive motor, 4 pressure vessel, 5 safety valve, 6 valve for adjusting the flow rate, 7 sound damper; P pressure, PD differential pressure, P_{el} power, n speed

Specification

- [1] comparison of driven machines for liquid and gaseous media
- [2] closed water circuit
- [3] 1 piston compressor
- [4] 4 pumps: piston pump, impeller pump, 2 centrifugal pumps
- [5] drive motor with variable speed
- [6] flow determined by level (water) or Venturi tube (air)
- [7] digital displays for pressure, differential pressure, temperature, speed and drive power
- [8] GUNT software for data acquisition via USB under Windows 10

Technical data

Piston compressor

- max. volumetric flow rate: 115L/min
- max. pressure difference: 10bar

2 centrifugal pumps

- max. flow rate: 60L/min, max. head: 18m

Piston pump

- max. flow rate: 14,6L/min
- system pressure is limited to max. 6bar

Impeller pump

- max. flow rate: 20L/min, max. pressure: 1,5bar

Drive motor, 4-pole

- max. power: 0,75kW
- nominal speed: 1370min⁻¹

2 pressure vessels: 10L, max. 10bar

2 water tanks: 60L, 10L

Measuring ranges

- speed: 0...2500min⁻¹
- power consumption: 0...1375W
- temperature: 0...200°C
- pressure: 1x 0...2bar; 1x 0...6bar; 1x 0...10bar
- differential pressure: 0...10mbar

230V, 50Hz, 1 phase

230V, 60Hz, 1 phase; 120V, 60Hz, 1 phase

UL/CSA optional

LxWxH: 2050x600x1550mm

Weight: approx. 205kg

Required for operation

PC with Windows recommended

Scope of delivery

- 1 trainer
- 1 compressor
- 4x pump
- 1 set of accessories
- 1 GUNT software + USB cable
- 1 set of instructional material

HM 299

Comparison of positive displacement machines and turbomachines

Optional accessories

for Remote Learning

GU 100

Web Access Box

with

HM 299W

Web Access Software