

IA 210

PLC application: materials handling process



Description

- automation fundamentals system
- handling demonstrator
- simulation of a punching process
- simulation of workpiece control

IA 210 is a compact teaching and practice unit for the control of a materials handling process using a PLC. Two processes can be simulated: a punching process, or workpiece control in the form of a sort operation. All components are in a clearly laid out design.

Black and white cylindrical workpieces are fed from a container onto a conveyor belt. On the belt is a reflex photoelectric proximity switch which differentiates between light and dark and feeds the white items to the pre-selected process (punching or sorting). The black workpieces are always carried to the end of the belt, where they drop into a collector.

Three 5/2-way solenoid valves, three double-acting cylinders and a pneumatic roller pushbutton can be operated via the PLC to execute the necessary steps: releasing the workpiece from the container; pushing the workpiece onto the conveyor belt; sorting or punching the workpiece. For punching, the workpiece is brought to a predefined position. The working cylinder can switch between sorting and punching modes by a simple sequence of actions.

The unit is designed for operation in conjunction with a PLC module. Use of PLC module IA 130 is recommended.

Learning objectives/experiments

- familiarisation with and analysis of an automated materials handling process
 - ▶ understanding and analysis of the mechanical, pneumatic and electrical functions
 - ▶ familiarisation with the symbols, terms and modes of representation of pneumatic and electrical function diagrams
 - ▶ familiarisation with automation components: cylinders, solenoid valves, photoelectric proximity switches
- familiarisation with the use of a PLC
 - ▶ basic methods of programming
 - ▶ adapting the program to the given handling process
- simulation of a punching process
 - ▶ conveyor belt is stopped for punching
 - ▶ conveyor belt also stops as soon as workpiece drops from belt end
- workpiece control simulation
 - ▶ light-coloured workpieces are separated out; dark items reach the belt end

IA 210

PLC application: materials handling process

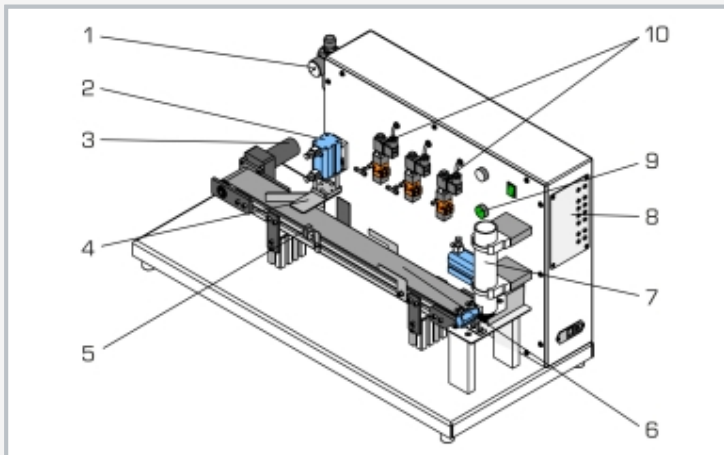

1 maintenance unit, 2 double-acting cylinder, 3 conveyor belt drive motor, 4 punching or sorting device, 5 reflex photoelectric proximity switch, 6 conveyor belt, 7 container for 11 workpieces, 8 electrical connections for solenoid valves and sensors, 9 display of limit switch, 10 5/2-way solenoid valve

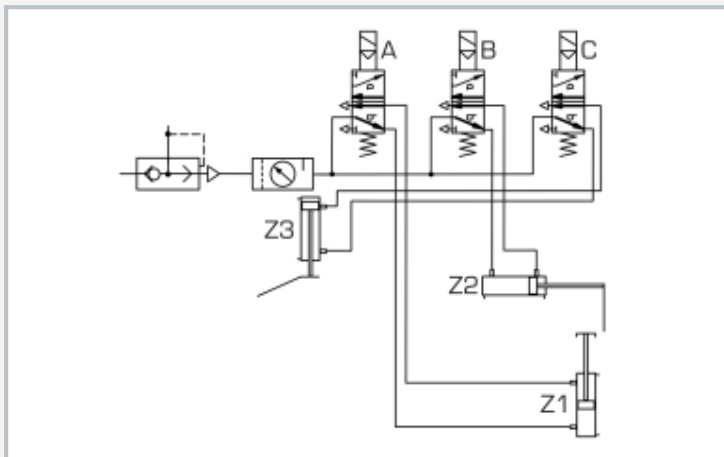

Pneumatic connection diagram



Electrical connections of the solenoid valves and sensors

Specification

- [1] compact unit for experiments in the field of automation
- [2] handling device with solenoid valves
- [3] double-acting cylinder (15mm stroke): fixing / discharge of workpieces to container
- [4] double-acting cylinder (80mm stroke): pushes workpiece onto conveyor belt
- [5] double-acting cylinder (40mm stroke): executes the process (sorting or punching)
- [6] conveyor belt with guide plates and DC motor
- [7] cylindrical Plexiglas storage container holding 11 workpieces
- [8] 15 workpieces made of Polyoxymethylene (POM): 10x white, 5x black
- [9] pneumatic components fitted with quick-release couplings for 4mm hoses
- [10] operation of actuators with compressed air
- [11] lab jacks to external PLC
- [12] set of laboratory cables and pneumatic hoses
- [13] compressed air supply: max. 6bar, 3bar recommended

Technical data

- 3 electrically operated 5/2-way valves
 - with spring return
 - with pilot valve

- Reflex photoelectric proximity switch
 - pnp, light-switching
 - 5...150mm

- Geared DC motor
 - reduction ratio: 142,5:1
 - nominal torque 5,92Nm
 - nominal speed: 22min⁻¹

Polyester weave conveyor belt
Workpieces, DxH: 40x20mm

- 230V, 50Hz, 1 phase
- 230V, 60Hz, 1 phase
- 120V, 60Hz, 1 phase
- UL/CSA optional
- LxWxH: 1000x450x580mm
- Weight: approx. 46kg

Required for operation

compressed air connection: min. 3bar

Scope of delivery

- 1 experimental unit
- 1 set of workpieces
- 1 set of laboratory cables
- 2 collecting tanks
- 1 set of instructional material

IA 210

PLC application: materials handling process

Optional accessories

IA 130

PLC module

WP 300.09

Laboratory trolley