

# MT 154

## Assembly exercise: shut-off valve



### Learning objectives/experiments

- design and function of a shut-off valve
- assembly and disassembly, including for the purposes of maintenance and repair
- reading and understanding engineering drawings
- planning and presentation of the assembly process
- familiarisation with various machine elements: thread mechanism, seals, packing gland
- material selection criteria
- together with the valves and fittings test stand MT 162
  - ▶ leak testing of the assembled valve

### Description

- **practical exercise based on the assembly of a shut-off valve**
- **broad scope of learning with interdisciplinary problems**
- **part of the GUNT Practice Line for assembly, maintenance and repair**

Shut-off valves of the type included in the MT 154 unit are used to shut-off and restrict the flow of media. They must be capable of total flow shut-off. The closing of the valve should be such that the volumetric flow does not suddenly drop to zero so as to prevent shock loads. The valve taper is moved by the spindle and ensures a metallic seal against the seating ring pressed into the housing. The spindle is sealed by a packing gland. The joint between the housing and the clamp cover is sealed by a flat seal.

The MT 154 project unit presents an introduction exercise to the area of assembly techniques. The assembly and disassembly processes can easily be completed within standard lesson times. Basic tools, all supplied with the kit, are required for assembly.

The unit is of most benefit in teaching if small groups of two to three students work independently. The group has a defined task to perform, with clear assignments to complete.

The comprehensive instructional material is oriented to practical needs. It includes a complete set of drawings with an overview drawing, parts list and single-part drawings.

Together with the valves and fittings test stand MT 162, the assembled valve can be subjected to a pressure test.

# MT 154

## Assembly exercise: shut-off valve



The illustration shows the shut-off valve fully assembled.

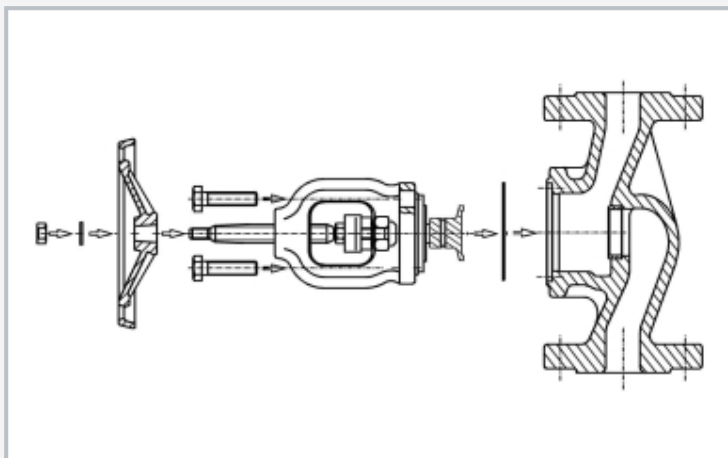

Shut-off valve assembly drawing

### Specification

- [1] assembly exercise for engineering training
- [2] shut-off valve PN16 as parts set, with associated set of small parts, in a sturdy case
- [3] shut-off valve consisting of housing, hand wheel, clamp cover, packing gland frame, taper and spindle
- [4] spindle sealing based on the gland principle
- [5] part of the GUNT Practice Line for assembly, maintenance and repair

### Technical data

Shut-off valve with flange connections:

- DN25
- PN16
- stroke: 13mm
- housing, hand wheel, clamp cover, packing gland frame: grey cast iron
- taper, seating ring, spindle, ring segment etc.: stainless steel

LxWxH: 600x450x180mm (case)

Weight: approx. 16kg

### Scope of delivery

- 1 kit
- 1 set of tools
- 1 set of small parts
- 1 case
- 1 set of instructional material, consisting of: technical description of system, complete set of drawings with lists of parts, description of assembly and disassembly sequences, also in relation to repair operations

# MT 154

## Assembly exercise: shut-off valve

Optional accessories

MT 162                    Hydraulic valves and fittings test stand