



GUNT FEMLine Fluid energy machines

HM 365 – Series for studying fluid machinery

GUNT FEMLine

A series for studying fluid machinery

In the GUNT product range, FEM stands for the German term "Fluid Energie Maschinen", which means fluid machinery. The term "line" refers to a GUNT equipment series. The GUNT-FEMLine equipment series was designed specifically to represent the great diversity of fluid energy machines. The series offers a variety of options to learn about and gain an in-depth understanding of this complex subject matter.

To ensure a high level of practical orientation of the devices, the GUNT-FEMLine was developed with industrial components. This allows students to practice on examples from industrial applications that they will also encounter in their future workplaces.

Examples from industry



Pump system



Oil pumps, for example, are used in internal combustion engines for engine lubrication



Internal combustion engines in everyday life

Devices from the GUNT-FEMLine

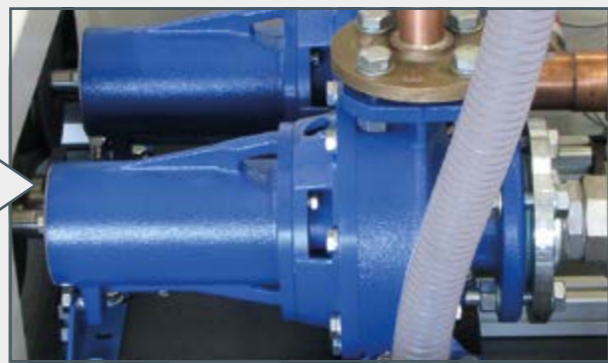

Centrifugal pumps

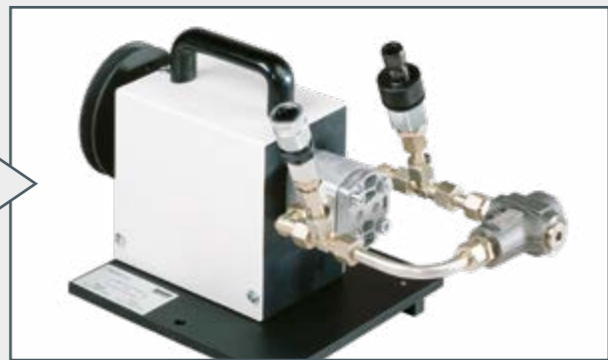

Positive displacement pumps

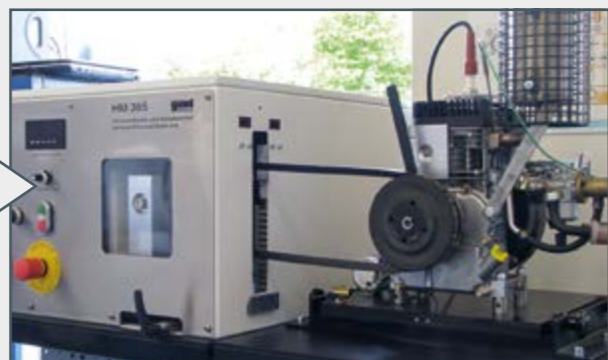

Internal combustion engines

Examples from industry



The rotor of a Francis turbine prior to installation

The Three Gorges Dam in China on the Yangtze River uses Voith Siemens Hydro Power Generation turbines.



Industrial refrigerating plant



Industrial compressed air generation plant



Blohm + Voss steam turbine

Devices from the GUNT-FEMLine



Francis turbine



Refrigeration system with open compressor

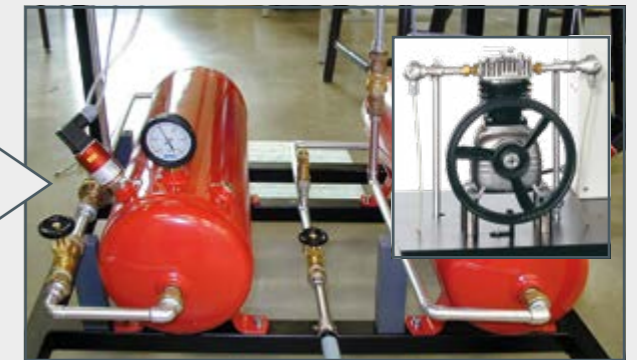

Single-stage piston compressor



Steam power plant with 2-cylinder steam engine and electrical steam generator

GUNT FEMLine

A series for studying fluid machinery



What are the requirements for future engineers in both industry and research?



How do GUNT training courses prepare students for their future working lives?

What are the benefits of a GUNT training course?

GUNT training courses are an important component of the education of engineers, because they convey essential practical knowledge.

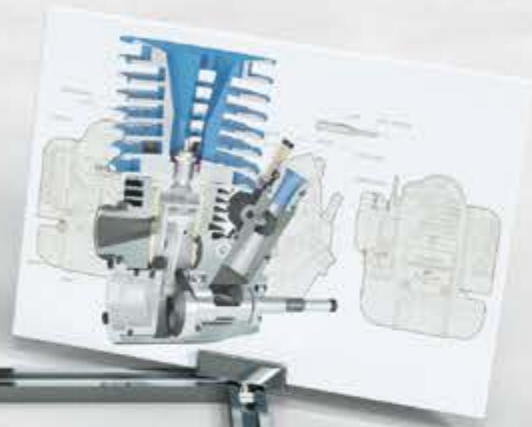

Theory
includes sectional views and design drawings to familiarise students with the details of the machines



Practice
with practical experiments, measurements and test results



Evaluation
of test results, for example with GUNT software



Practical application
in the professional world



e.g. on engine test stands in the automotive industry

Advantages of the GUNT-FEMLine

Modularity



- exchangeable modules with a different thematic focus
- multiple combinations possible
- ONE base module can be used for all training courses

Flexibility



- flexibility due to the modular system
- adaptable to any curriculum thanks to the flexible layout options
- flexible upgrade: add additional accessories or training courses to the series one by one

Mobility



- all FEMLine trainers are built on wheels and can be moved around without effort
- accessories are easily connected to the base module with quick-release fasteners
- quick and easy exchange of accessories
- most trainers are equipped with a closed water and/or oil circuit and can be used regardless of conditions at the lab

Size



- the series covers a wide range of industrial driving and driven machines
- every fluid energy machine in this series offers a broad spectrum of experiments
- despite the size and capacity of the fluid machinery in this series, the trainers are easy to handle, set up, and store

Deepening of knowledge



- in-depth knowledge and comprehensive understanding of the complex subject area of fluid machinery
- clearly structured courses with a logical educational concept
- comprehensive range of experiments on every fluid energy machine

Practical relevance



- consistent use of industrial components
- the laboratory experiments are realistic and based on practical experimentation

Software support



- every experimental unit is equipped with a device-specific software from GUNT
- convenient evaluation of experiments with the software

The modular system of the GUNT FEMLine

The GUNT-FEMLine equipment series offers fluid energy machines from all common machine classifications: driven and driving machines, turbomachines and positive displacement machines, and thermal and hydraulic machines. This variety is possible thanks to the modular design of the series: The GUNT-FEMLine consists of all kinds of different modules that can be combined flexibly.

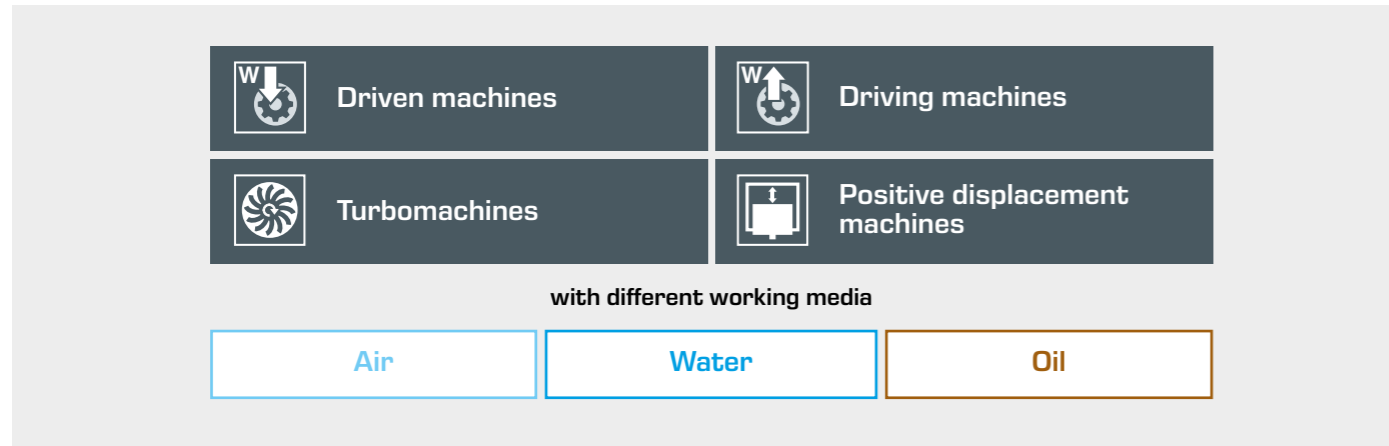

You have the choice! You are welcome to put together **your own training course – perfectly suited to your curriculum!** Take advantage of the modular design of this equipment series! If you need help realising your ideas and putting together your training courses, our development team will be happy to support you. Below, we have compiled a few suggestions on how the modules could be combined.

Driven machines <ul style="list-style-type: none"> centrifugal pumps HM 365.11 to .14 positive displacement pumps HM 365.16 to .18 HM 365.21 to .24 axial-flow pump HM 365.45 compressor (refrigeration system) ET 165 compressor (air) ET 513 	Driving machines <ul style="list-style-type: none"> internal combustion engines CT 150 to CT 153 Pelton and Francis turbine HM 365.31 steam engine ET 813
Turbomachines <ul style="list-style-type: none"> centrifugal pumps HM 365.11 to .14 axial-flow pump HM 365.45 Pelton and Francis turbine HM 365.31 	Positive displacement machines <ul style="list-style-type: none"> positive displacement pumps HM 365.16 to .18 HM 365.21 to .24 internal combustion engines CT 150 to CT 153 compressor (refrigeration system) ET 165 compressor (air) ET 513 steam engine ET 813
Cyclic processes <ul style="list-style-type: none"> refrigeration system ET 165 steam power plant ET 813 	
Thermal fluid energy machines <p>Working medium: compressible fluids</p> <ul style="list-style-type: none"> internal combustion engines CT 150 to CT 153 refrigeration system ET 165 single-stage piston compressor ET 513 steam power plant ET 813 	Hydraulic fluid energy machines <p>Working medium: incompressible fluids</p> <ul style="list-style-type: none"> water pumps HM 365.11 to .19 oil pumps HM 365.21 to .24 axial-flow pump HM 365.45 Pelton and Francis turbine HM 365.31

GUNT places this at your disposal:

Based on the function and mode of operation of fluid machinery, GUNT has compiled the following training courses.

Each course covers a broad range of experiments on selected topics. The fluid energy machines that form part of a training course are selected in such a way that the learning objectives build upon each other. Within a training course, students can compare different types of fluid energy machines with the same mode of action or operation. The consistent use of industrial

components underscores the high level of practical relevance and increases the recognition factor for students as they start their careers later on.

The following pages contain a detailed description of the training courses.

Water pumps

HM 365.10 plus HM 365.11 to HM 365.19, HM 365.45

- comparison of different rotodynamic pumps and positive displacement pumps
- application, interaction and switching of different pumps

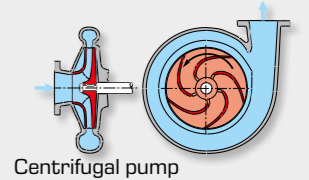

Oil pumps

HM 365.20 plus HM 365.21 to HM 365.24

- introduction to and comparison of different types of oil pumps
- delivery mechanisms for viscous fluids



Turbines

HM 365.32 plus HM 365.31

- introduction to different types of turbines
- comparison of a Pelton and Francis Turbine

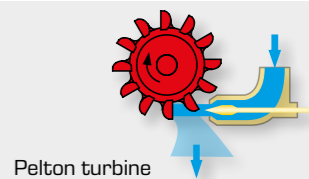

Internal combustion engines

CT 159 plus CT 151 to CT 153 Introduction to and comparison of different single cylinder engines:

- petrol and diesel engines
- 4-stroke and 2-stroke engines

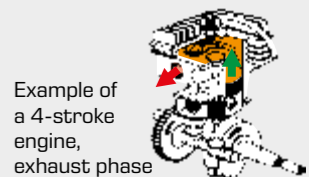

Systems engineering

ET 165, ET 513, ET 813 Introduction to different systems:

- refrigerating plant
- compressed air generation plant
- steam power plant



An overview of the GUNT FEMLine



	Complete trainer	Fluid energy machine	Fluid energy machine	Complete trainer	
Water pump training	<p>HM 365 HM 365.11 HM 365.10</p>	<p>HM 365.11 Centrifugal pump, standard design HM 365.12 Centrifugal pump, self-priming design HM 365.13 Centrifugal pump, multistage HM 365.14 Centrifugal pumps, series and parallel connected</p>	<p>HM 365.31 Pelton and Francis turbine</p>	<p>HM 365 HM 365.31 HM 365.32</p>	Turbine training
	<p>HM 365.45 Axial-flow pump</p> <p>The axial-flow pump HM 365.45 does not require an additional supply unit</p>	<p>HM 365.15 Side channel pump HM 365.16 Lobe pump HM 365.17 Reciprocating piston pump HM 365.18 Gear pump HM 365.19 Vane pump</p>	<p>CT 150 Four-stroke petrol engine CT 151 Four-stroke diesel engine CT 153 Two-stroke petrol engine</p>	<p>HM 365 CT 151 CT 159</p>	Engine training
Oil pump training	<p>HM 365 HM 365.23 HM 365.20</p>	<p>HM 365.21 Screw pump HM 365.22 External gear pump HM 365.23 Vane pump HM 365.24 Internal gear pump</p>	<p>ET 813.01 Electrical steam generator ET 813 Two-cylinder steam engine ET 513 Single-stage piston compressor ET 165 Refrigeration system with open compressor</p>	<p>HM 365 ET 813 ET 813.01 HM 365 ET 513 HM 365 ET 165</p>	Plants and systems training

GUNT FEMLine

Water pump training part 1 roto dynamic pumps

Water pumps are driven machines. They can be designed as positive displacement pumps or rotodynamic pumps. The selection of the correct pump type is crucial when designing industrial systems or installing a pump. This is why it is important

that future engineers understand the characteristics of pumps and interpret diagrams to be able to distinguish between the different types of pumps.

1st part Rotodynamic pumps as water pumps:

The centrifugal pump is the most common water pump. It belongs to the group of rotodynamic pumps. The water pump training from GUNT offers four different types of centrifugal pumps, based on which students can learn about the mode operation and the differences of these types:

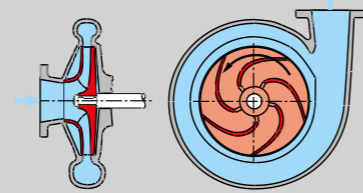

Standard design centrifugal pump

Standard pumps are pumps that are designed in accordance with international standards. The standard defines rating schemes and key dimensions so that standard pumps from different manufacturers can be exchanged without replacing the piping and ground plate.



HM 365.11
Centrifugal pump, standard design

Centrifugal self-priming pump

Self-priming pumps are able to suck in and transport air and water. In contrast to a simple centrifugal pump, they can also be started if there is air in the intake line. This is possible because of an additional side-channel suction stage that removes the air from the intake line and creates the negative pressure that is needed to suck in the fluid.



HM 365.12
Centrifugal pump, self-priming

4-stage centrifugal pump

In centrifugal pumps with multiple stages, several impellers are arranged in series. This allows the pump to overcome large differences in head.



HM 365.13
Centrifugal pump, multistage

Different circuit configurations for centrifugal pumps

In complex systems, pumps can be connected in series or in parallel. In series operation the head is the sum of the individual heads; in parallel operation the flow rates of the individual pumps are combined.



HM 365.14
Centrifugal pumps, series and parallel connected

Side channel pump

Side channel pumps form a category between positive displacement pumps and rotodynamic pumps. During the suction phase the side channel pump operates according to the positive displacement principle. As soon as the suction process is over, the side channel pump starts working like a centrifugal pump. The centrifugal force of the rotating impeller separates the fluid and gas. Side channel pumps are therefore self-priming pumps.



HM 365.15
Side channel pump

Axial-flow pump

Axial-flow pumps are also known as propeller pumps. Axial-flow pumps come with fixed blades and with variable blades. The flow passes through the impeller in axial direction. In axial-flow pumps, the pressure is not built up by the effect of centrifugal force but, like the aerodynamic principle, by the propeller blade. Propeller pumps are not self-priming pumps. They are used when high flow rates and a small head are needed. The typical areas of application for propeller pumps are drainage systems, wastewater treatment plants and cooling water supply systems.

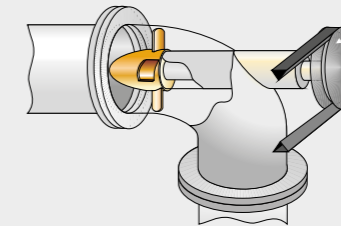

HM 365.45
Axial-flow pump

Sectional models and assembly training



HM 700.17 Cutaway model: centrifugal pump

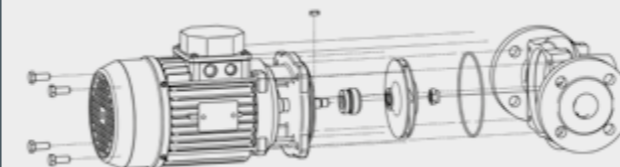

MT 185 Assembly & maintenance exercise: in-line centrifugal pump exploded drawing of an inline centrifugal pump

To complete the water pump training, GUNT offers **sectional models and assembly and maintenance training** for different pumps. Please refer to catalogue 4 for more information on these devices.

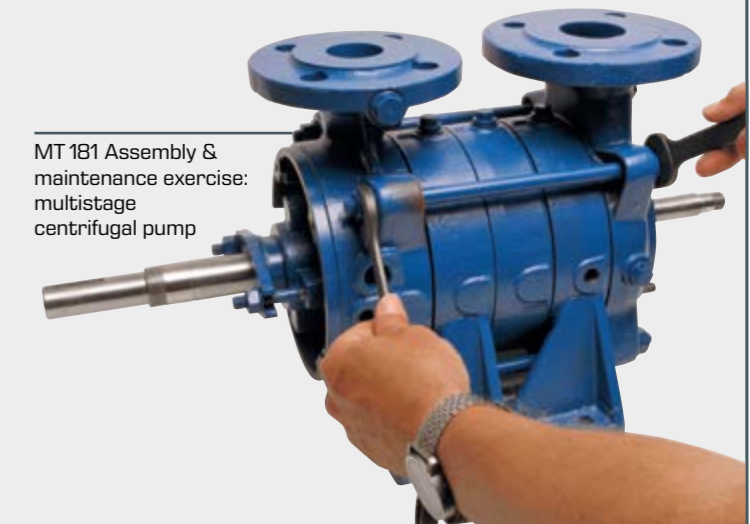

MT 181 Assembly & maintenance exercise: multistage centrifugal pump

GUNT FEMLine Water pump training part 2 positive displacement pumps

The HM 365.10 Supply unit for water pumps from GUNT is a trainer for studying the properties of different water pumps under realistic operating conditions. Some of the pumps are powerful industrial pumps. Combined with the drive unit HM 365 and the different pump units, the supply unit HM 365.10 is an ideal pump trainer.

HM 365.10
Supply unit for
water pumps

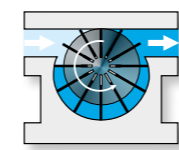

Vane pump

Vane pumps are also known as rotary vane pumps. They can be used for both liquid and gaseous media. There are vane pumps with constant displacement volumes and with adjustable displacement volumes. The pump consists of a housing, in which an eccentric cylindrical rotor rotates. Rotary vanes are spring-mounted to radial guides inside the rotor. During operation, the spring-force ensures that the rotary vanes run along the inner wall of the housing and an enclosed space is formed between them. The pumping medium is transported between the rotary vanes and the housing wall.



HM 365.19 Vane pump

2nd part

Positive displacement pumps as water pumps:

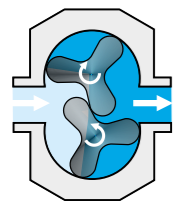

Lobe pump

In a lobe pump two non-contact pistons rotate in two cylindrical chambers. With each revolution, they deliver the same volume. Lobe pumps are used for delivering highly viscous and highly abrasive media.



HM 365.16 Lobe pump

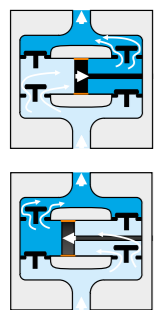

Reciprocating piston pump

The most simple type of reciprocating piston pump consists of a piston moving in a cylinder with one inlet and one outlet valve. Depending on the internal cylinder pressure, the valves open the inlet and outlet to the stroke chamber.



HM 365.17 Reciprocating piston pump

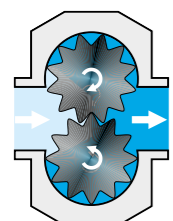

Gear pump

Essentially, gear pumps consist of three components: a housing with an inlet and outlet for the fluid and two gears, one of which powers the other one. Gear pumps differ depending on their internal design. The most common gear pump, the external gear pump, is used here as an example.



HM 365.18 Gear pump

Sectional models and assembly training



HM 700.20 Cutaway model: piston pump

To complete the water pump training, GUNT offers **sectional models and assembly and maintenance training** for different positive displacement pumps: Please refer to catalogue 4 for more information on these devices.

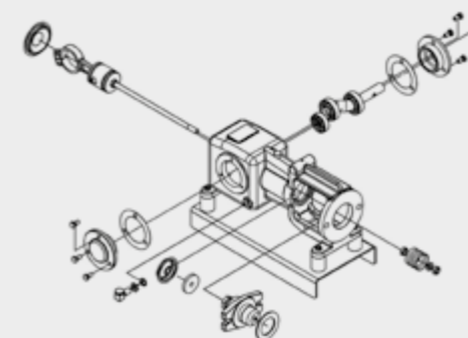

Exploded drawing of the piston pump



MT 184 Assembly & maintenance exercise: piston pump

GUNT FEMLine Oil pump training

Oil pumps are driven machines. The selection of the correct oil pump mainly depends on the viscosity or, its inverse, the fluidity of the oil. In refineries centrifugal pumps are used to deliver large volumes of thin or low viscosity oils, such as petroleum. Oils with a higher viscosity are transported with positive displacement pumps. Moreover, oil pumps are used to perform mechanical

work and for lubrication and cooling purposes. In hydraulic systems, oil is used to transmit forces. The pumps that are needed for this purpose must be able to achieve high pressures in order to generate large lifting or forming forces. They are, for example, used in lifting platforms or metal presses.

This training course deals with oil pumps that transport oil with the help of enclosed volumes according to the positive displacement principle. Depending on requirements and demand, different oil pump designs are used. The most commonly used oil pumps are **gear pumps**. Essentially, gear pumps consist of the following components: a housing with an inlet and outlet for the oil and two gears, one of which powers the other one. Depending on their internal design, gear pumps are categorised as follows:

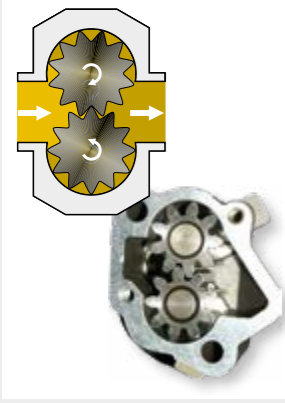

External gear pump

In an external gear pump, two gears rotate in opposite directions in a housing. The pumping medium is transported between the gears and the housing. Due to their simple, robust setup these pumps are relatively cost-efficient. External gear pumps are very common in the automobile industry.



HM 365.22
External gear pump

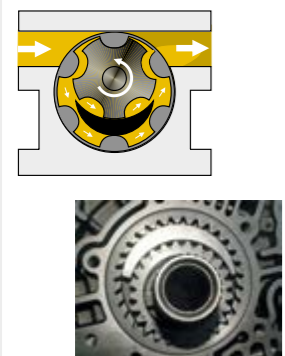

Internal gear pump

Internal gear pumps are also known as crescent pumps. They are characterised by their low pulsation, high efficiency, low level of noise and medium-high operating pressures. An internal gear drives an external toothed ring. Since the driving gear is mounted on an eccentric bearing, clearances result in the gaps between the gear and the toothed ring. These clearances form the delivery volume. A crescent-shaped seal between the gear and the ring forms the enclosed volume that is necessary to reach the required pressure.



HM 365.24
Internal gear pump

Toothed ring pump

Toothed ring pumps are also known as Eaton pumps or gerotor pumps. The internal gear runs eccentrically along the internal gearing of the toothed ring and powers this ring. The volume of the displacement chamber between the gaps changes, and thereby allows the pumping medium to be transported.

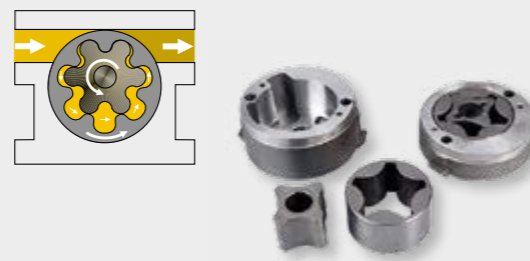

Screw pump

Screw pumps are able to provide continuous delivery of even viscous media without pulsation or turbulence. Their pump housing contains two or more rotors that rotate in opposite directions, with an external screw thread profile. As the threads of the screws engage, the fluid is transported. Depending on the thread pitch, very high pressures can be achieved. Screw pumps run very smoothly, which is why they are often used in lifts and as fuel pumps in oil burners.



HM 365.21
Screw pump

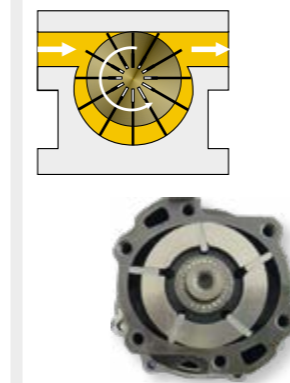

Vane pump

Vane pumps are also known as rotary vane pumps. They can be used for both liquid and gaseous media. In some vane pumps, the displacement volume is adjustable. These pumps consist of a housing, in which an eccentrically installed cylinder rotates (rotor). Rotary vanes are spring-mounted to radial guides inside the rotor. During operation, the spring-force ensures that the rotary vanes run along the inner wall of the housing and an enclosed space is formed between them. The pumping medium is transported between the rotary vanes and the housing wall.



HM 365.23
Vane pump

Sectional models and assembly training



HM 700.22 Cutaway model: gear pump

To complete the oil pump training, GUNT offers **sectional models and assembly and maintenance training** for different positive displacement pumps: Please refer to catalogue 4 for more information on these devices.



MT 186 Assembly & maintenance exercise: gear pump

GUNT FEMLine Turbine training

Turbines are driving machines. They convert the internal energy of a fluid into mechanical energy. Depending on where the energy conversion takes place, we distinguish between action turbines and reaction turbines.

Turbines are used in power plants to generate electrical power through connected generators, and in power units to generate thrust.

The complete trainer consists of three components:

- 1 HM 365 Universal drive and brake unit
- 2 HM 365.31 Pelton and Francis turbine
- 3 HM 365.32 Turbine supply unit



HM 365 is in generator mode and slows down the turbine with a V-belt. The generator converts the resulting power into electrical power.

On the work surface of the Turbine Supply Unit HM 365.32, one of the turbines HM 365.31 is placed and connected via hoses. The closed water circuit means that the trainer is mobile and can be used independently from the water system. The flow rate and/or the pressure can be adjusted by means of a flow control valve.

For more information on this training course please refer to the data sheets for the corresponding devices in chapter 2.

The GUNT-FEMLine turbine training introduces participants to an action turbine and a reaction turbine. The action turbine is a Pelton turbine, and the reaction turbine is a Francis turbine. The course explores and compares the different principles of operation of these turbines.



Assembly of a Pelton turbine at the Walchensee power plant in Germany (Voith Siemens Hydro Power)



Francis turbine, deinstalled

Turbine training: comparison of the principles of operation

Action turbine (Pelton turbine)

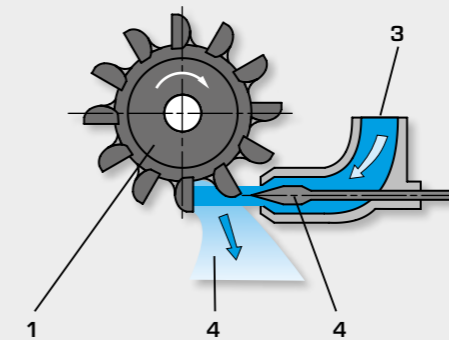

- 1 rotor,
- 2 distributor,
- 3 water inlet,
- 4 water outlet

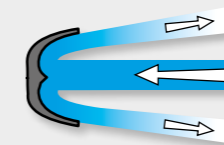

The water jet changes direction in the blade without changing velocity

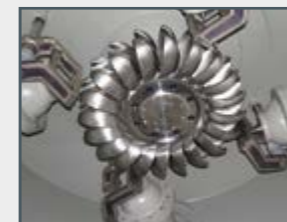

In a Pelton turbine, the conversion of the pressure energy of water into kinetic energy takes place completely at the distributor. Since the entire pressure difference is reduced exclusively in the nozzle, the pressure in the rotor remains constant. The turbine power is controlled by adjusting the nozzle cross-section.

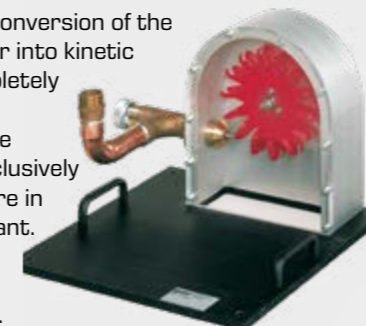

HM 365.31 Pelton and Francis turbine

Reaction turbine (Francis turbine)

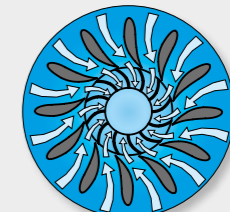
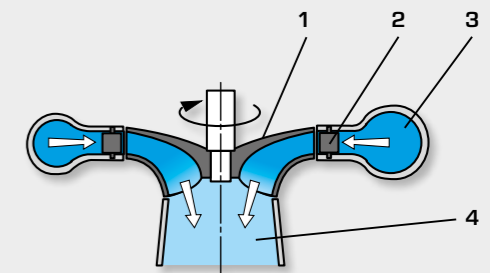

The flow cross sections change. Acceleration of the water jet in the guide vane and the blade



In a Francis turbine, the conversion of the pressure energy into kinetic energy takes place inside the distributor and the rotor. The pressure at the rotor inlet is higher than the pressure at the rotor outlet. The turbine power is controlled by adjusting the guide vanes.



GUNT FEMLine Internal combustion engine training

Internal combustion engines are thermal driving machines. Internal combustion engines are used to power railway and motor vehicles, aircraft or watercraft and stationary machinery.

The GUNT-FEMLine offers four different internal combustion engines in a capacity range up to 3,0kW: 4-stroke diesel and petrol engines with variable compression, and a 2-stroke petrol engine. The engines are supplied with fuel and air via a modular test stand, CT 159. The exhaust fumes are discharged to the outside via hoses. The engines are connected to the HM 365 Universal Drive and Brake Unit with a V-belt. HM 365 is first used to start the engines. While the engines are running, HM 365 is operated in generator mode, thus braking the engines.

The engines can be examined under full load or under partial load conditions. The characteristic diagram is determined with variable load and speed. The interaction of the brake and engine can also be examined in this context.

The **electronic indicating system** is a good way to gain an in-depth understanding of how an engine works. Special pressure sensors record the pressure in the cylinder chamber.

These data provide important information on the combustion process in the engine. In industrial applications, indicating systems are used to optimise the combustion process. The data are used to create the indicator diagram.

The indicating system helps identify the individual strokes of the engine. The process of ignition or an ignition attempt, and the gas exchange can be examined. Cranking without ignition can be simulated while examining the processes inside the cylinder chamber. The idling behaviour of diesel and petrol engines can be compared. The indicating system can be used to carry out a thermodynamic analysis of the engine.

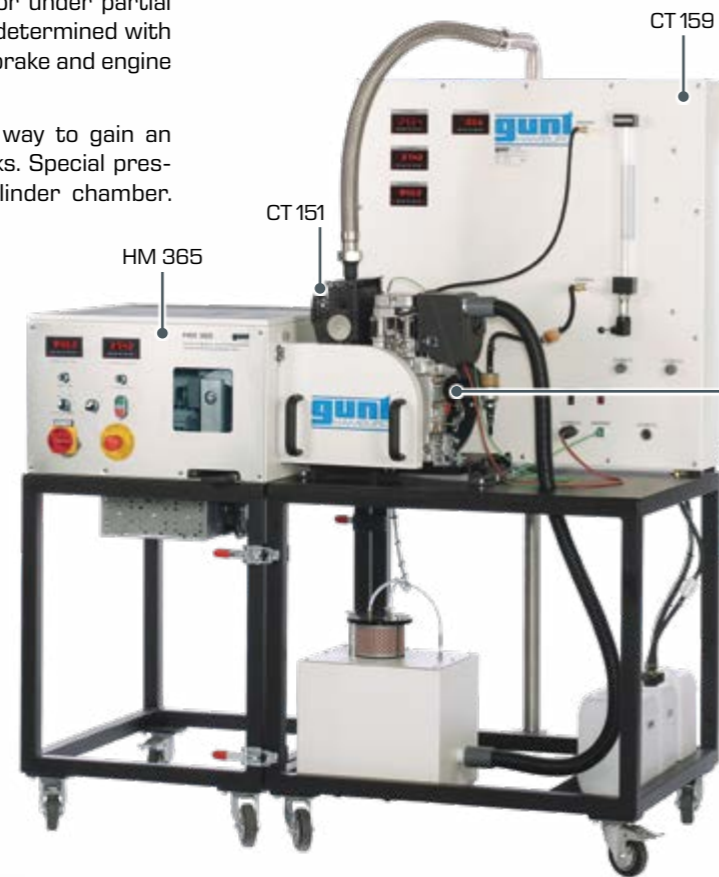

Modern GUNT software for Windows with comprehensive visualisation functions:

- process schematic for all engines with real-time display of all measured and calculated variables
- display of up to four characteristics at the same time
- representation of characteristics: select any assignment for the axes of the diagram
- storage of measuring data
- selection between four preset languages
- easy connection to a PC via USB

HM 365 + CT 159 + test engine (CT 150 – CT 153) including PC data recording

- characteristics for full and partial load
- determination of friction loss in the engine
- comparison of diesel and petrol engines
- comparison of 2-stroke and 4-stroke engines
- 4-stroke petrol engine with variable compression

Extended range of experiments with

- exhaust gas analysis with CT 159.02 and / or
- electronic indication with PC-based data acquisition with CT 159.01 + engine-specific pressure sensor with TDC sensor (CT 159.03, CT 159.04 or CT 159.05)
- p-V diagram
- p-t diagram
- pressure curve during gas exchange
- determination of the indicated performance
- determination of mechanical efficiency



**CT 150
Four-stroke petrol engine**
Air-cooled, single-cylinder, 4-stroke petrol engine with external carburation

CT 159.03
Pressure sensor and TDC sensor

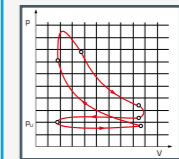

CT 159.01
Electronic engine indicating system

Pressure measurement in the cylinder chamber of an internal combustion engine



CT 159.02
Exhaust gas analysing unit

Measurement of the composition of exhaust gases (CO, CO₂, HC, O₂), the fuel / air ratio λ and the oil temperature of the engine.



CT 151
Four-stroke diesel engine

Air-cooled, single-cylinder, 4-stroke diesel engine with direct injection

CT 159.04
Pressure sensor and TDC sensor



CT 153
Two-stroke petrol engine

Air-cooled, single-cylinder, 2-stroke petrol engine with diaphragm carburettor

CT 159.05
Pressure sensor and TDC sensor

GUNT FEMLine Systems engineering training

A system or plant consists of several coordinated technical components, e.g. machines, instruments, valves and fittings, and connection elements. The combination of the components must fulfil a clearly defined task. The components are related based on functional, control engineering, or safety engineering aspects.

During the development of a system design these components must be coordinated. Possible interdependencies between the components must be taken into account in order to achieve a functional overall system.

The systems engineering training presents three systems with completely different tasks: a **compression refrigeration system**, a **compressed air generation system**, and a **steam power plant**. All of these systems require the base module HM365.

The experimental plants simulate real laboratory-sized plants. This allows a broad spectrum of experiments with reproducible results and a teaching style that is as close to reality as possible.

Every device of the GUNT-FEMLine comes with GUNT software that is specially designed for the requirements of the trainer. A USB interface transfers the measurement data to the PC. Using the software the measurement data can be clearly displayed on the PC. Time dependencies can be recorded and stored.

For more information on this training course please refer to the data sheets for the corresponding devices in chapters 3 and 4.



Industrial compressed air generation plant: ET 513 Single-stage piston compressor

- operating principle of a piston compressor
- measurement of volumetric flow rate and pressures
- power measurement
- determination of efficiency
- plotting of compressor characteristic
- determination of intake flow and volumetric efficiency

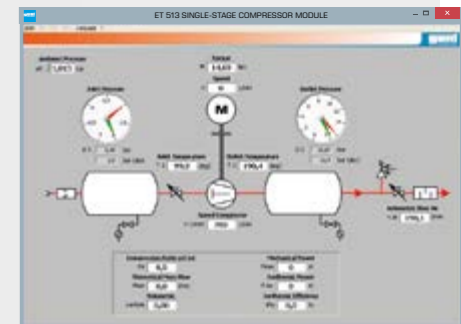

- The software displays:
- pressures
 - air flow rate
 - compressor speed
 - temperatures
 - volumetric efficiency and isothermal efficiency

HM 365 Universal drive and brake unit

ET 513 Single-stage piston compressor

Compression refrigeration system: ET 165 Refrigeration system with open compressor

- principle of function of a compression refrigeration system
- open compressor with variable speed
- measuring the mechanical drive power
- determination of the compressor efficiency
- effect of the compressor flow rate on the refrigeration circuit



HM 365 Universal drive and brake unit

ET 165 Refrigeration system with open compressor

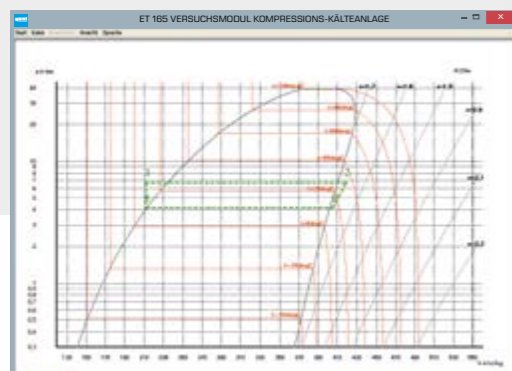

Output via the software: representation of the cyclic thermodynamic process in the log p-h diagram

Steam power plant: ET 813 Steam engine and ET 813.01 Steam generator

- operating principle of a piston steam engine
- cyclic process of a steam power plant
- power measurement
- energy balances
- determination of efficiency
- electrical steam generator: quick start-up, fully automatic, reliable, no exhaust gases, no fuel necessary
- no special authorisation needed (in EC countries)



HM 365 Universal drive and brake unit

ET 813 Two-cylinder steam engine

ET 813.01 Electrical steam generator

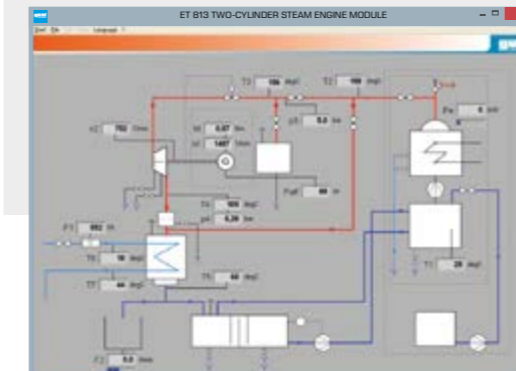

- The following data are represented:
- temperatures
 - pressure and pressure differences
 - steam engine speed
 - mechanical and electrical power

Equipment series in the GUNT product range

The final chapter of the catalogue provides an overview of the available equipment series from the fluid machinery product range.

Equipment series

Labline

A Labline example:
HM 280 Experiments
with a radial Fan



FEMLine

Base module HM 365
Universal drive and brake unit (left)
HM 365.10 Supply
unit for water pumps (right side, with pump)



You can find more
from fluid machinery here:



» Fluid machinery

GUNT developed equipment series with two goals in mind:

- on one hand a series covers an entire subject area
- on the other hand detailed knowledge of individual requirements and aspects of the subject area can be conveyed

How do the GUNT equipment series achieve this goal?

- definition of one subject area per series
- emphasis on different questions of the subject area
- development of experimental units corresponding to the subject area
- the different devices of a series are all thematically related to each other

Therefore each device

- is dedicated to a specific topic and a related set of questions
- forms a self-contained unit

Advantages of series:

- detailed understanding and knowledge of a subject area
- experimental results of different devices can be directly compared
- regardless of spatial requirements, operation of the device is secured by means of a self-contained system
- any of the experimental units that are part of the series can be selected and combined as you please
- as your laboratory grows, you can continue to add other devices to complement the series

Labline and FEMLine

Why does the GUNT programme include TWO series on the subject area of fluid machinery?
The concepts of the two series are very different:

Labline

- small, easy to handle experimental units
- easy transportation
- transparent housings
- the same device can be used both for to give demonstrations in the lecture hall or the classroom and to perform experiments in the lab
- the experimental units are compact and inexpensive, allowing you to furnish your lab with more experimental workstations

Labline turbines

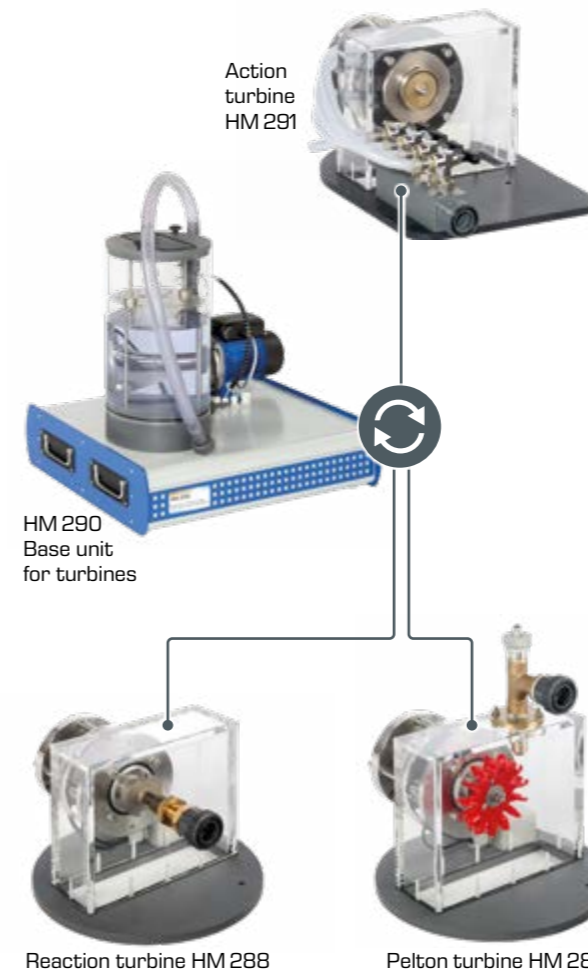

FEMLine

- the FEMLine experimental units are much larger
- high level of practical relevance through use of real fluid machinery
- very versatile range of experiments
- the comprehensive and in-depth range of experiments using industrial components completely covers an individual subject area

FEMLine turbines

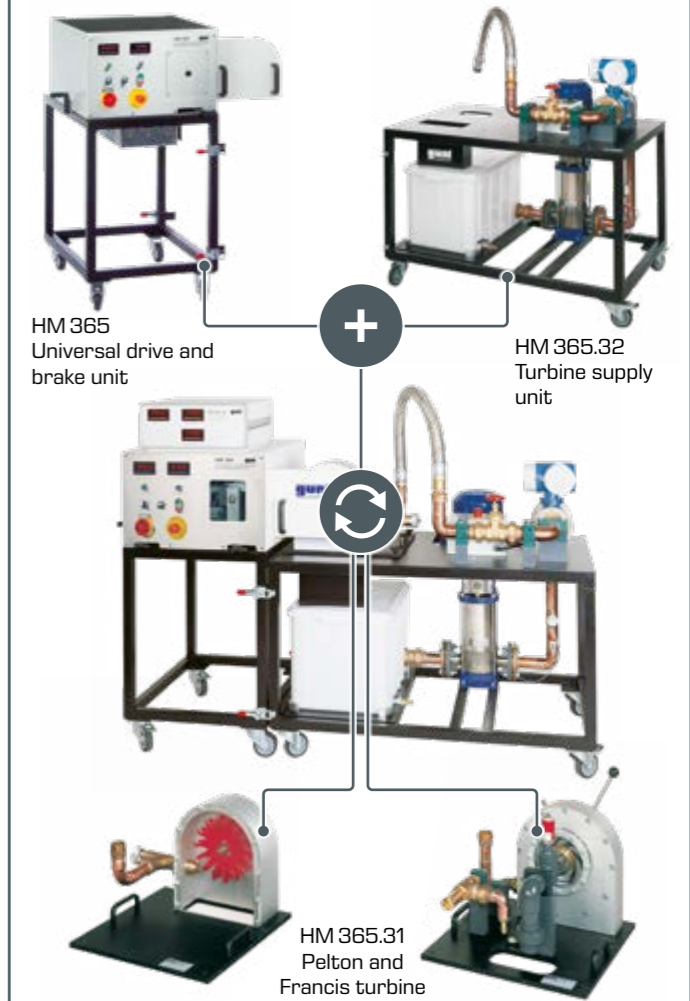

Options for combining the base unit with different experimental units

The complete GUNT programme



Engineering mechanics and engineering design

- statics
- strength of materials
- dynamics
- machine dynamics
- engineering design
- materials testing

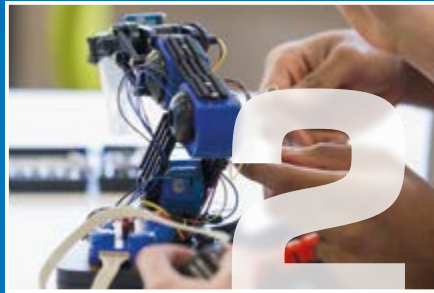

Mechatronics

- engineering drawing
- cutaway models
- dimensional metrology
- fasteners and machine parts
- manufacturing engineering
- assembly projects
- maintenance
- machinery diagnosis
- automation and process control engineering



Thermal engineering

- fundamentals of thermodynamics
- heat exchangers
- thermal fluid energy machines
- internal combustion engines
- refrigeration
- HVAC



Fluid mechanics

- steady flow
- transient flow
- flow around bodies
- components in piping systems and plant design
- turbomachines
- positive displacement machines
- hydraulic engineering



Process engineering

- mechanical process engineering
- thermal process engineering
- chemical process engineering
- biological process engineering
- water treatment



2E Energy & Environment

- | Energy | Environment |
|----------------------------------|-------------|
| ■ solar energy | ■ water |
| ■ hydropower and ocean energy | ■ air |
| ■ wind power | ■ soil |
| ■ biomass | ■ waste |
| ■ geothermal energy | |
| ■ energy systems | |
| ■ energy efficiency in buildings | |

Contact

G.U.N.T. Gerätebau GmbH
Hanskampring 15-17
22885 Barsbuettel
Germany

+49 40670854-0
sales@gunt.de
www.gunt.de



Visit our website
www.gunt.de