

Didactic concept

GUNT-DigiSkills 2



Digitalisation in the world of work – new requirements for education

Designing training in industrial metalworking professions

Our learning projects help you to implement the new requirements

Didactic concept for a complex learning project

Dimensional metrology

Planning training elements and teaching courses



Table of contents

1	The exercise structure	04
1.1	The storage system	05
1.2	The GUNT Media Center	06
1.3	The E-Learning course	07
1.4	Digital worksheets	07
2	Learning objectives	08
3	Example presentation of selected exercises	08
3.1	Functional contexts of components	08
3.2	Hole/shaft basis fit systems	10
3.3	ISO GPS, introduction to geometrical product specifications	11
3.4	Software-supported analysis	14
3.5	Processing technical relationships digitally	15
3.6	Familiarisation with sealing elements	15
3.7	Technical terminology	16
3.8	...a trainee's thoughts	16
4	Product list and tender specifications	17
5	Summary – Outlook	18

Foreword

More than any other group, the industrial metalworking and electrical professions are in the spotlight when it comes to **digitalisation** and **Industry 4.0**. Education must respond to the new requirements with a concrete implementation of the Industry 4.0 relevant fields of competence and training content. Conventional and innovative techniques coexist and must both be mastered.

GUNT can help you with these complex educational tasks. Our practical, work process-oriented learning projects, which are perfectly suited to developing digital skills, are available to you in the form of the **GUNT-DigiSkills product line**.

Notes:

This document does not make any scientific claims. It is designed to be practical, as a direct stimulus for modern teaching and process-oriented education. The digitalisation goals apply everywhere: in training organisations as well as in vocational schools or colleges.

The author's aim is to generate dialogue with you.

There is no need for expensive investments in complex networked model systems for manufacturing and robotics in your laboratories and workshops. With our GUNT-DigiSkills concepts, we show you that training can be easier, cheaper and more tangible.

The motivation and learning progress of your students/trainees will reward you as a trainer or as a teacher if you use GUNT-DigiSkills learning projects.

The GUNT-DigiSkills 2 learning project

The topic of this learning project is **dimensional metrology as a main element of quality inspection**. The two target learning areas can be found in all curricula of a wide variety of metalworking professions. The learning project contains four practice kits for systematic and staged learning of the fundamentals:

- PT 102 Dimensional metrology, spacer plate
- PT 104 Dimensional metrology, angle piece
- PT 105 Dimensional metrology, shaft
- PT 109 Dimensional metrology, hub

The test objects have been selected according to didactic criteria – from the simple to the demanding – and designed for a variety of different test procedures.

To take the step into the real world of industry, GUNT offers two further practice kits with technical functionality or specific applications:

- PT 107 Dimensional metrology, flange housing
- PT 108 Dimensional metrology, output shaft

The test objects in these practice kits are original test objects from the MT 123 spur and worm gear assembly exercise. The students/trainees are familiarised with a real-world technical environment with many aspects that go beyond the narrower view of metrology: functionality, materials, GPS (Geometrical Product Specifications), design, etc.

Each system with the DigiSkills 2 series can be used individually. For each system, you and your students/trainees have access to extensive material in digital formats:

- by accessing the GUNT Media Center
- by using the E-Learning courses for each dimensional metrology practice kit

An extensive pool of pre-designed exercises is available online in the GUNT Media Center. These are exercises that go build on the E-Learning course and that can be worked on online. The exercises are designed in such a way that in most cases they can be completed in a 45-minute lesson.



About the author

Rudolf Heckmann is Managing Director at G.U.N.T. Gerätebau GmbH, and is responsible for programme development and didactic concepts. Education: Mechanical engineering and physics, 10 years teaching experience in the vocational/technical sector. Extensive scientific work on engineering pedagogy and subject didactics. Founder of the international GUNT Technical Academy.

GUNT-DigiSkills learning projects

Skill Level	
1	Engineering drawing
2	Dimensional metrology
3	Preventive maintenance
4	Experimental plants
5	Robotics and automation

The practice kits with test objects



The test objects in the PT102 to PT109 practice kits are designed according to didactic criteria. They do not fulfil a defined purpose and are not functionally related.

The test objects in the PT 107 and PT 108 practice kits have a technical purpose. They are functionally related. These test objects are based on real-world machine elements.

1 | The exercise structure

The **PT102 Dimensional metrology, spacer plate** is used as an example to present the exercise structure, the storage system and the GUNT Media Center

The PT102 practice kit contains 10 different test objects, which appear similar. The test objects are marked with ordinal numbers 1 to 10.



Test object: spacer plate 10

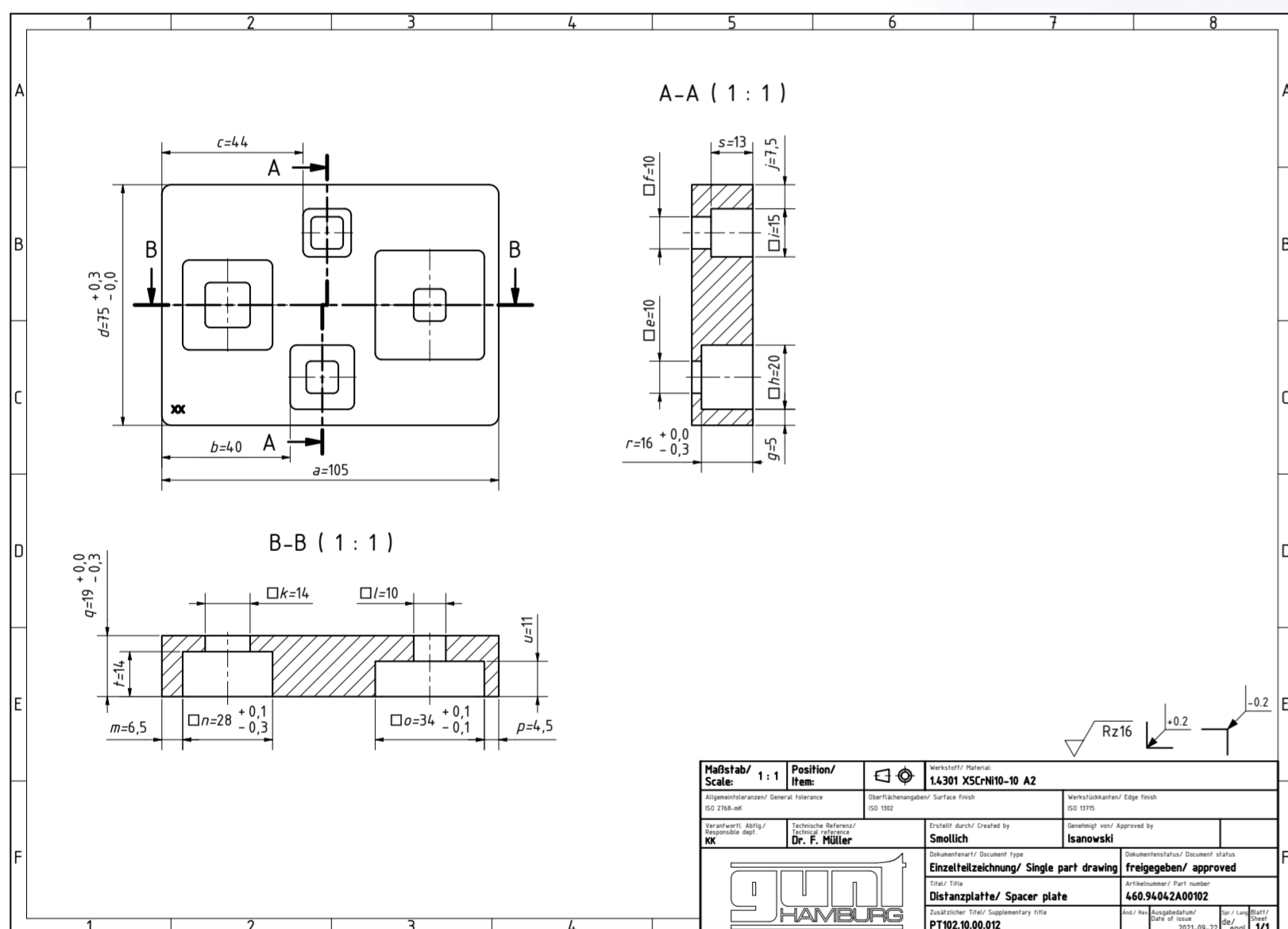

All dimensions of a test object, in this case a spacer plate, are measured by reference to the main drawing. If the dimensions are described as completely "good", the spacer plate passes the quality inspection without any objections.

A complete test run comprises the measurement of 21 lengths for each of the test objects. The test procedure is presented in detail with appealing animations in the E-learning course.

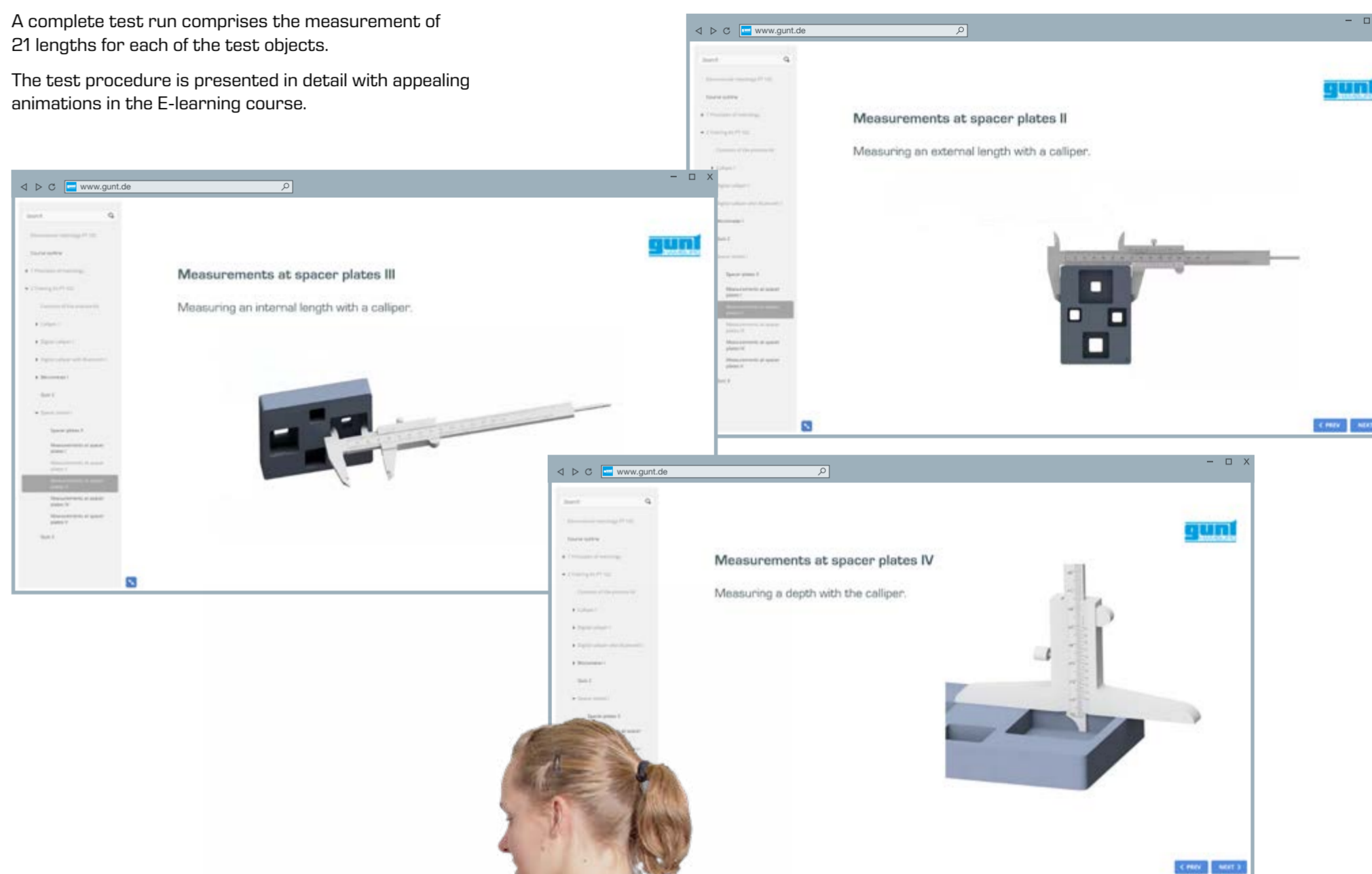

1.1 | The storage system



Keep everything tidy, neatly arranged and easy to transport and maintain an overview to ensure constant and immediate availability.

Each practice kit is clearly laid out and well protected in its own storage system. The test objects and the necessary test equipment are included.

The test objects only appear the same at first glance: Three of the 10 test objects are manufactured in such a way that they meet all the conditions of the main drawing: they are considered as "good", the others as "reject".

Seven of the 10 test objects are manufactured in such a way that they have individual variances that are to be determined in the exercise.



1 | The exercise structure

1.2 | The GUNT Media Center

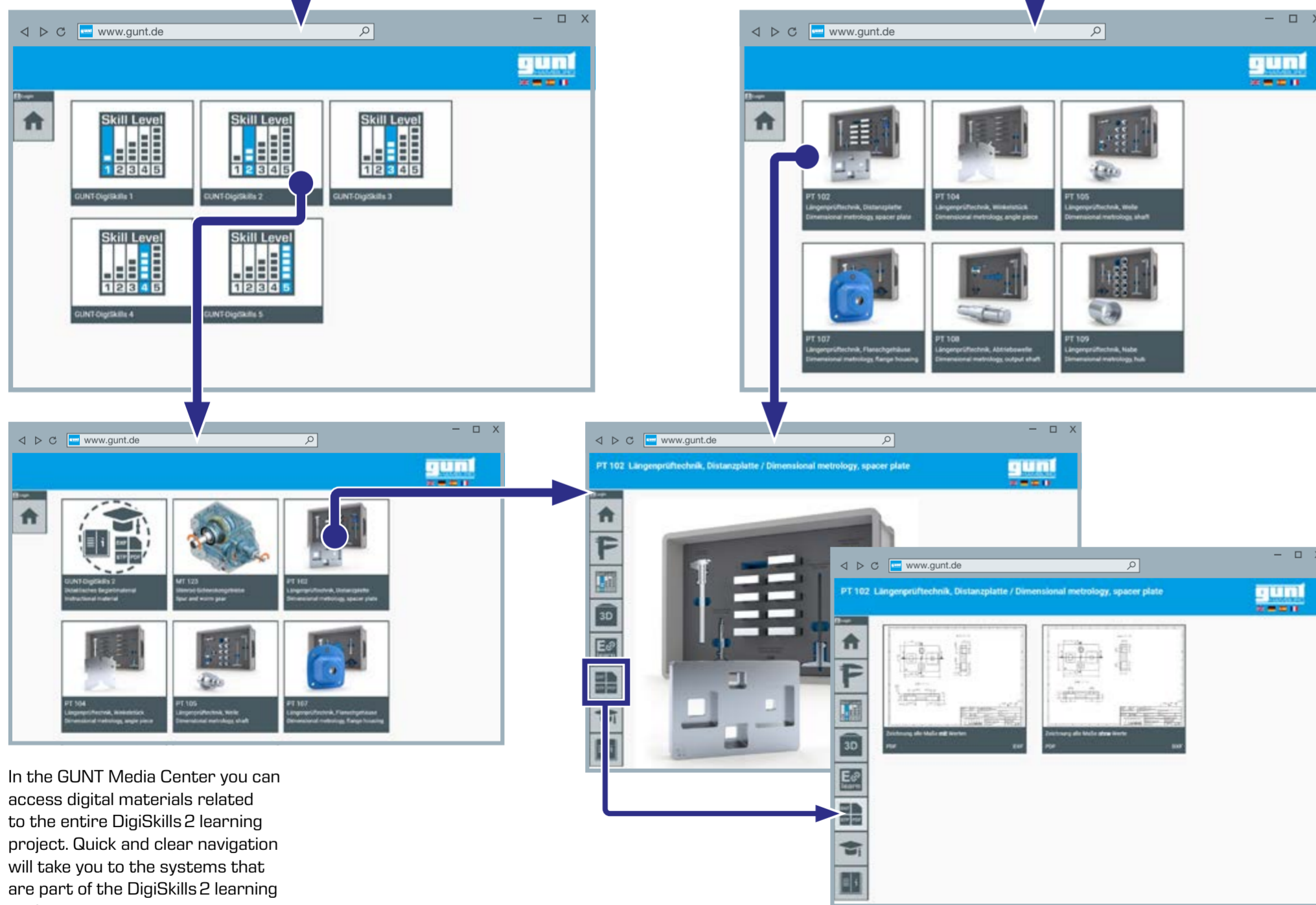

In the GUNT Media Center you can access digital materials related to the entire DigiSkills 2 learning project. Quick and clear navigation will take you to the systems that are part of the DigiSkills 2 learning project.

Here you will find comprehensive digital materials for the PT 102 to PT 109 practice kits:

- the main drawing in PDF, DXF, STP format
- access to the E-Learning course
- worksheets and solutions, which are offered in addition to the E-Learning course
- animations
- data sheets for the test equipment

1.3 | The E-Learning course

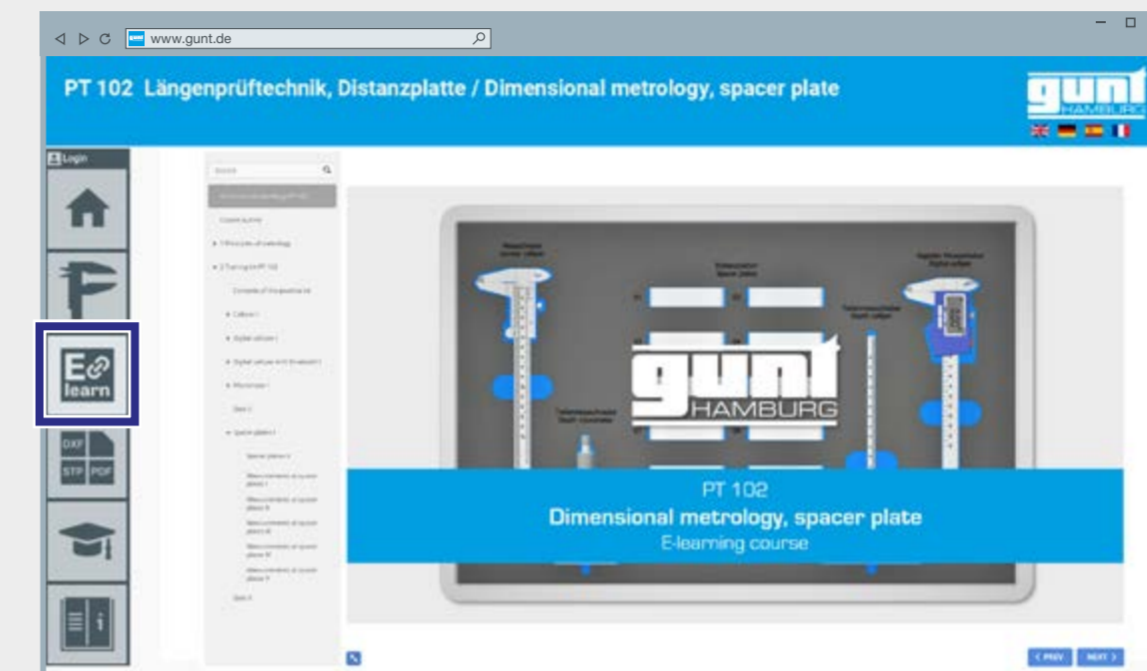

For each practice kit, you have full access to the appropriate and comprehensive E-Learning course, which is individually tailored to the training system. This also applies to your students and trainees.

Main features of the E-Learning course:

- fundamentals of dimensional metrology
- knowledge check with a quiz at certain points of the course
- concrete exercises and information for each practice kit
- dynamic graphics with plenty of interesting animations

Most importantly, it is not just some theoretical course. GUNT offers an E-Learning course that is fully tailored to the training systems. A perfect synthesis between hardware and educational software.

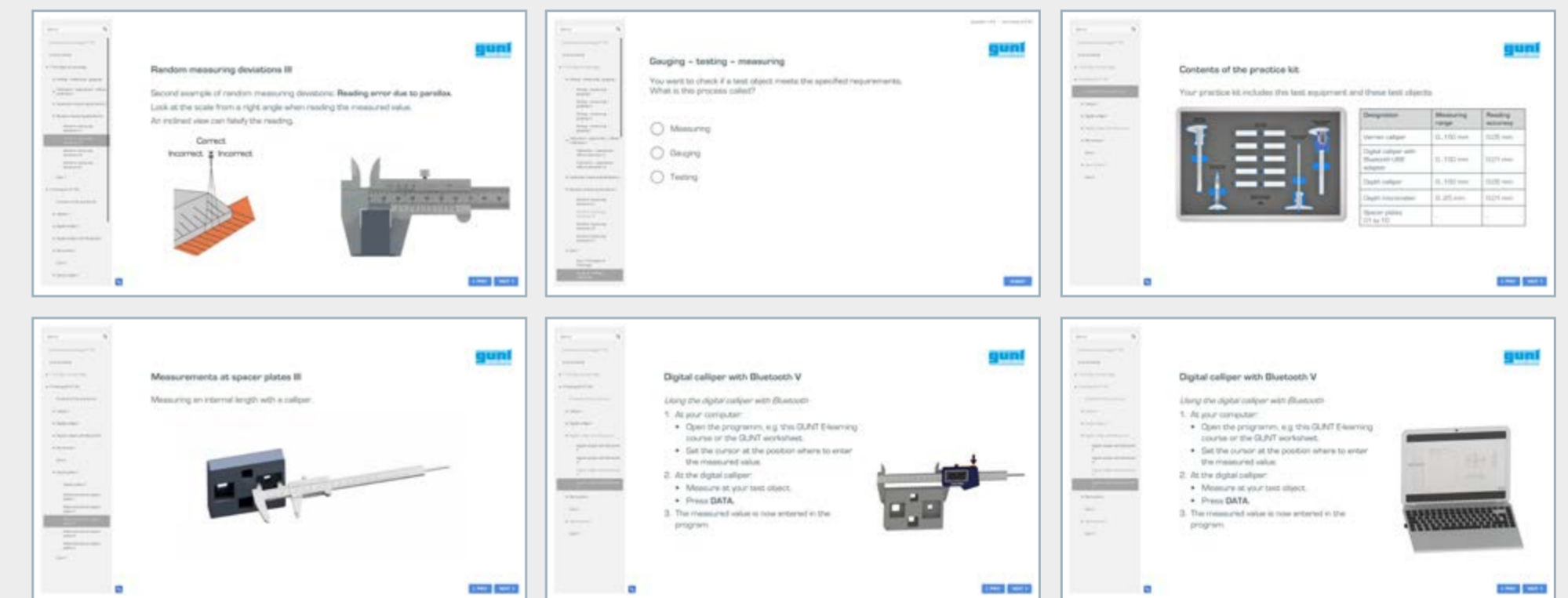

1.4 | Digital worksheets

Students or trainees will find a digital worksheet for each test object in the GUNT Media Center. Once the measurement task has been completed, the worksheet is used for further digital communication: e.g. students/trainees e-mail the solution to the teacher or save the file in designated folders.

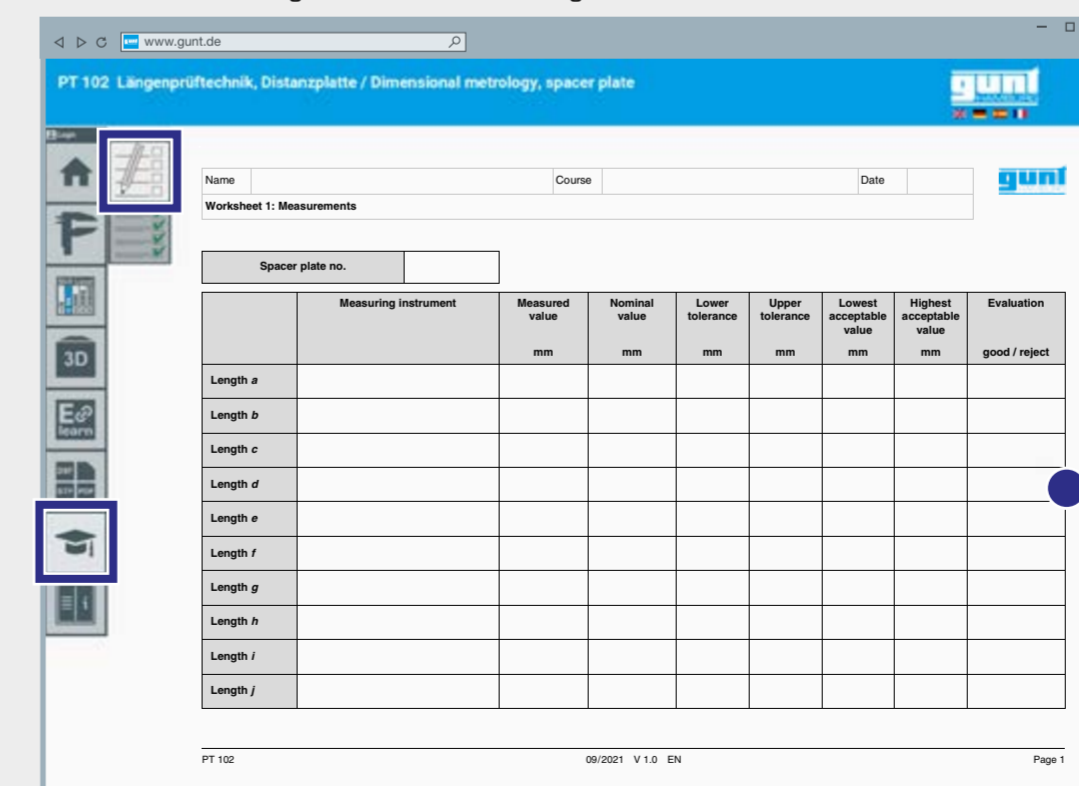

Spacer plate no.		Measured value	Nominal value	Lower tolerance	Upper tolerance	Lowest acceptable value	Highest acceptable value	Evaluation
mm		mm	mm	mm	mm	mm	mm	good / reject
Length a	Vernier caliper, digital caliper	105.1 - 105.3	100.0	-0.3	+5.3	104.7	105.3	good
Length b	Vernier caliper, digital caliper	40.4 - 40.6	40.0	-0.3	+0.3	39.7	40.3	reject
Length c	Vernier caliper, digital caliper	44.0 - 44.2	44.0	-0.3	+0.3	43.7	44.3	good
Length d	Vernier caliper, digital caliper	74.7 - 74.9	75.0	0.0	+0.3	75.0	75.3	reject
Length e	Vernier caliper, digital caliper	9.8 - 10.1	10.0	-0.2	+0.2	9.8	10.2	good
Length f	Vernier caliper, digital caliper	9.8 - 10.1	10.0	-0.2	+0.2	9.8	10.2	good
Length g	Vernier caliper, digital caliper	5.2 - 5.4	5.0	-0.1	+0.1	4.9	5.1	reject
Length h	Vernier caliper, digital caliper	19.5 - 19.7	20.0	-0.2	+0.2	19.8	20.2	reject
Length i	Vernier caliper, digital caliper	14.3 - 14.7	15.0	-0.3	+0.3	14.8	15.2	good
Length j	Vernier caliper, digital caliper	7.4 - 7.6	7.5	-0.2	+0.2	7.3	7.7	reject

Teachers/trainers can access the solution in the GUNT Media Center for each test object. Access to solutions is password protected.

2 | Learning objectives

Analysis of the learning objectives for working with the PT 102 to PT 109 practice kits at a glance:

Traditional technical content	Development of digital skills
<ul style="list-style-type: none"> ■ fundamentals of dimensional metrology: testing, measuring, gauging ■ systematic and random errors ■ familiarisation with basic tools and test equipment: <ul style="list-style-type: none"> ▶ vernier calliper ▶ external micrometer ▶ depth micrometer ▶ fine dial gauge ▶ radius gauge ▶ depth calliper ▶ digital calliper (internal, external, depth) with Bluetooth adapter ▶ universal goniometer ▶ slip gauge ■ general tolerance according to ISO 2768-m ■ specifications for surface marking, e.g. roughness depth Rz ■ familiarisation with the basics of the GPS concept (Geometrical Product Specifications) and the main associated standards ■ familiarisation with fit systems ■ familiarisation with general structure of a spur and worm gear; isolate the test objects of PT 107 and PT 108 from the overall context 	<ul style="list-style-type: none"> ■ using digital learning media, familiarisation with and using web-based training (WBT) ■ independent information gathering via web portals or search engines, including using the GUNT Media Center ■ familiarisation with file formats commonly used in engineering, e.g. PDF, DXF, STP ■ using mobile devices: tablet, smartphone ■ create or edit drawings, protocols, work plans using standard industry software or MS Office applications ■ familiarisation with assistance, simulation, diagnosis or visualisation systems, e.g. QR code, CAD viewer tool ■ digital measuring instrument with interface and data transfer, understanding manufacturer documentation

3 | Example presentation of selected exercises

Each of the PT 102 to PT 109 practice kits has its own, very detailed E-Learning course, which present the fundamentals of dimensional metrology as well as the concrete exercises. This is a pre-structured learning path. Below, GUNT would like to give you some ideas of what exercises beyond these might look like if you use several practice kits from dimensional metrology and the MT 123 spur and worm gear assembly kit in your teaching. This is equivalent to a DigiSkills 2 setup. The content of DigiSkills2 opens up many possibilities for you to design your lessons freely and is sure to generate many ideas of your own.

3.1 | Functional contexts of components

Overall aim of the exercise

The functional contexts of components of the spur and worm gear are to be recognised by using the GUNT Media Center. The PT107 and PT108 practice kits each study one test object, which has been taken from MT123 spur and worm gear assembly kit. The aim of this exercise is to explore the technological environment of these two test objects:

- familiarisation with the gear as a whole
- recognise the closer functional relationship of the two components (test objects)
- familiarisation with and use of the comprehensive digital tools and information paths of the GUNT Media Center

...we'll describe this path "step by step"



Using the GUNT Media Center for the exercise

1 in the GUNT Media Center, select the MT 123 gear

2 click on the "Drawing set" button to go to the component groups

3 select component group 1 and open the STP file

A click with the mouse highlights the output shaft. The output shaft from MT 123 is the test object in the PT 108 practice kit.

The STP file opens and the two test objects from the PT 107 and PT 108 practice kits are clearly visible. Use the "Model browser" button to highlight the two test objects with a mouse click.

A click with the mouse highlights the flange housing. The flange housing from MT 123 is the test object in the PT 107 practice kit.

Click on the "Explode model" button to understand the overall context, the structure and function of the spur and worm gear unit.

Final note

The GUNT Media Center, especially the AutoCAD Viewer Tool, offers almost endless, graphically appealing display options, which are of high didactic value and very flexible. You don't have to be a specialist to use this pool of information: students and trainees learn quickly and intuitively.

3 | Example presentation of selected exercises

3.2 | Hole/shaft basis fit systems

Overall aim of the exercise

Familiarisation with fit systems according to DIN 7154 and DIN 7155 and general tolerances according to ISO 2768-m. For this exercise you will find all manufacturing drawings of all gear parts in the GUNT Media Center.

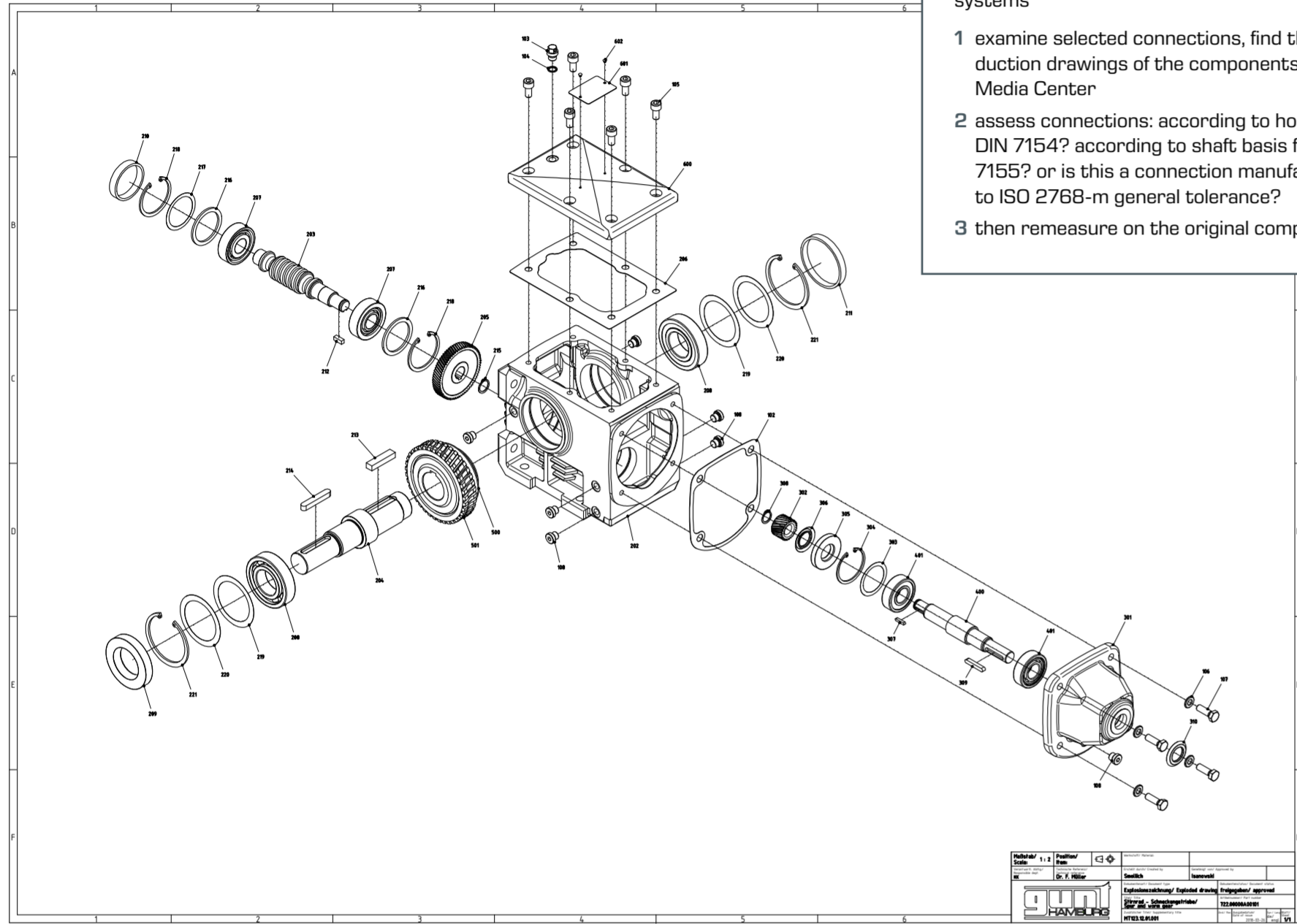

Task:
Understand and be able to explain hole/shaft basis fit systems

- 1 examine selected connections, find the relevant production drawings of the components from the GUNT Media Center
- 2 assess connections: according to hole basis fit system DIN 7154? according to shaft basis fit system DIN 7155? or is this a connection manufactured according to ISO 2768-m general tolerance?
- 3 then remeasure on the original components

This task is part of the fundamental knowledge for skilled workers in the relevant metalworking professions. Understanding can be acquired, repeated or deepened. Always with reference to real-world parts for which the standard-compliant drawings are available in the GUNT Media Center.

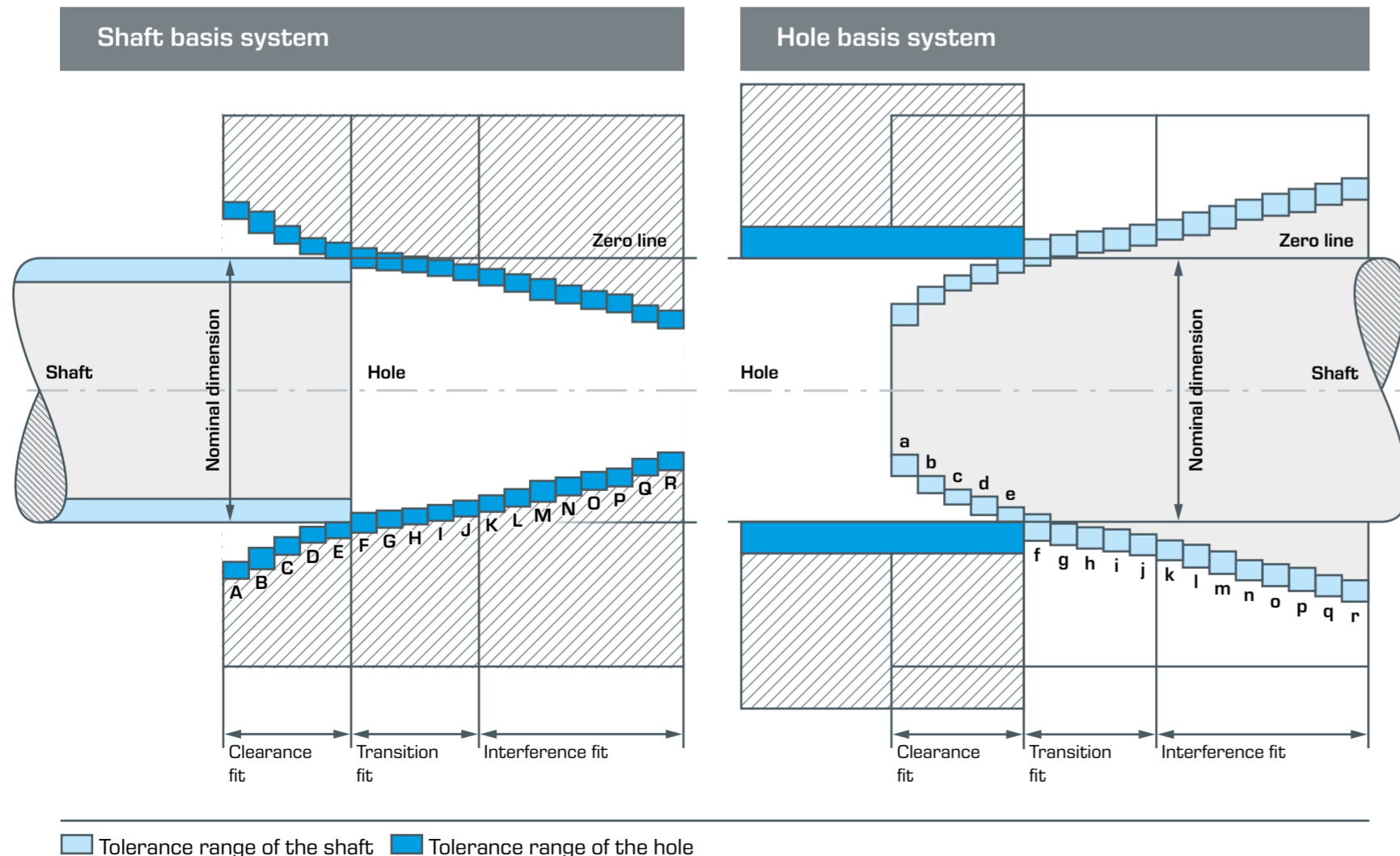

Light blue box: Tolerance range of the shaft; Dark blue box: Tolerance range of the hole

3.3 | ISO GPS, introduction to Geometrical Product Specifications

The fundamentals:

ISO GPS is the most important standardisation system in technical communication. All standards dealing with the requirements for the geometry of components (workpieces) are a part of it. The **Geometrical Product Specification (GPS)** is the basis for communication between design, manufacturing and quality assurance. The aim is to ensure the functionality and usability of components. Misunderstandings – both technical and contractual – should be excluded.

The interchangeability of components is a fundamental factor of industrial manufacturing. With regard to Industry 4.0, uniform drawings and data – with precisely specified requirements for the workpieces – are a basis for cooperation, including from an international perspective. ISO GPS is the system for **describing and checking workpiece properties**, such as size dimension, orientation, location, form, surface characteristics, etc.

Skilled workers in training for one of the metalworking professions, technical product designers or quality inspectors need a good overview of the current ISO GPS standards system in order to be able to assess and communicate from a technical perspective. Our complex learning project DigiSkills 2, dimensional metrology, makes it possible to convey in a concrete and practical way the basic features of the ISO GPS concept through effective and descriptive exercises.

This presentation here should not be regarded as a worksheet for concrete exercises. We want to show teachers/trainers approaches to the topic of ISO GPS when the different systems from the DigiSkills 2 learning project are available.

Two processes, **specification process** and **verification process**, are distinguished, but they are interrelated.

Specification process

The specification process is the process that takes place in the definition (development) of a product. The design intent is made concrete by certain GPS properties. **The specification process is the responsibility of the design department.** According to DIN EN ISO 17450-2:2013, it comprises the following steps:

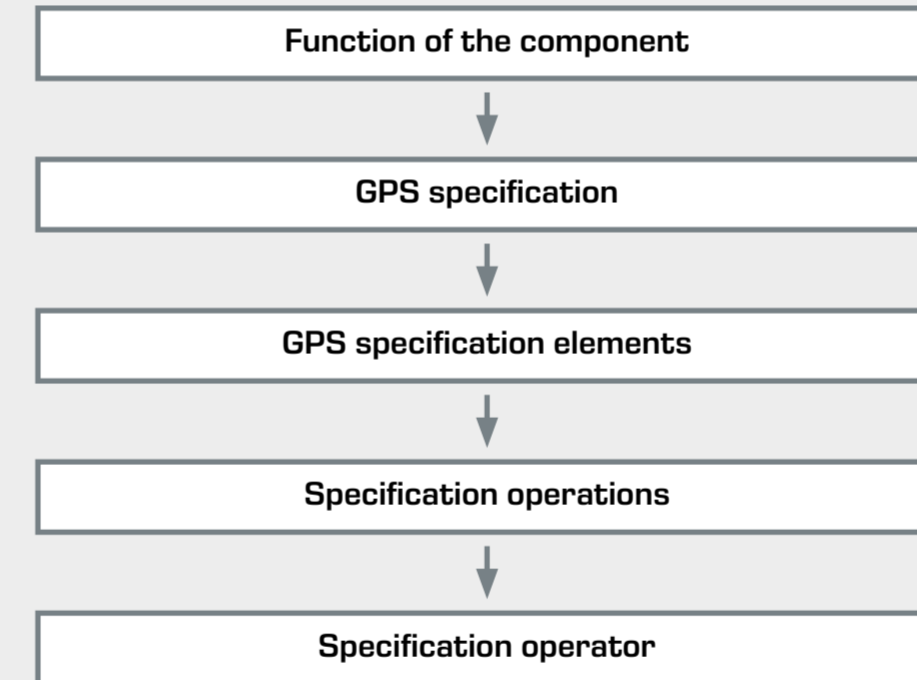

Verification process

The verification process takes place after the manufacture of an actual component. The aim is to verify the geometrical properties on the real workpiece: quality inspection to determine conformity. **The verification is the responsibility of the quality inspection department (test engineering).** Conformity is determined by comparing the specified properties to the results of the tests. DIN EN ISO 14253-1:2018 lays down rules for the demonstration of conformity or non-conformity with the specifications.

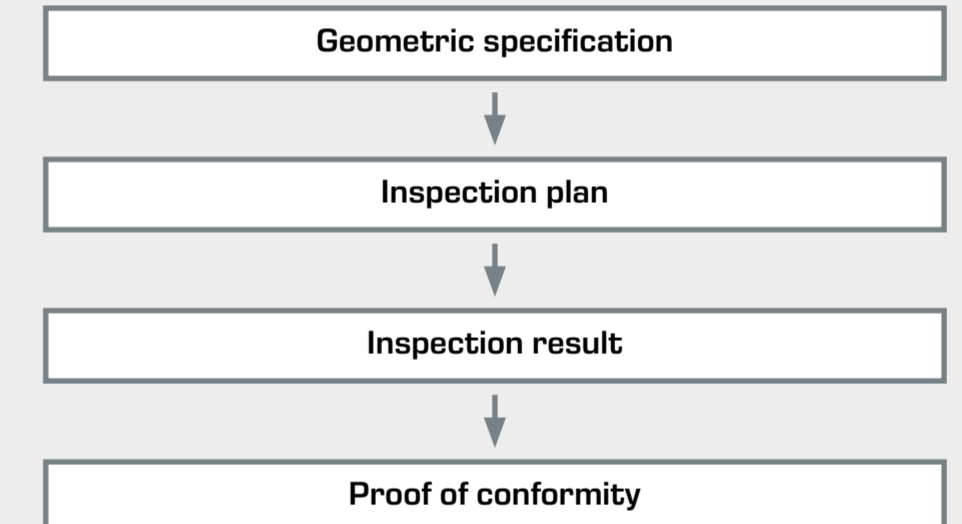

The GUNT Media Center provides standardised production drawings for all the practice kits in the DigiSkills2 range. This allows us to deal with the elements of the specification process.

The PT practice kits from DigiSkills 2 are primarily tailored to the topic of dimensional metrology, with graded demands from simple to challenging. The test objects from the PT practice kits are ideally suited for the verification process. All standard-compliant drawings are available.

The GUNT E-Learning course offers numerous exercises lasting from 45 to 90 minutes. Or you can use additional exercises offered in the GUNT Media Center.



3 | Example presentation of selected exercises

Task:

The output shaft from the MT 123 spur and worm gear is also the test object from the PT 108 practice kit. The following task is a comprehensive exercise for ISO GPS:

- 1 find information on all standard-compliant symbols (elements) and explain them thoroughly
- 2 arrange the information in tabular form

This and many other drawings can be found in the GUNT Media Center

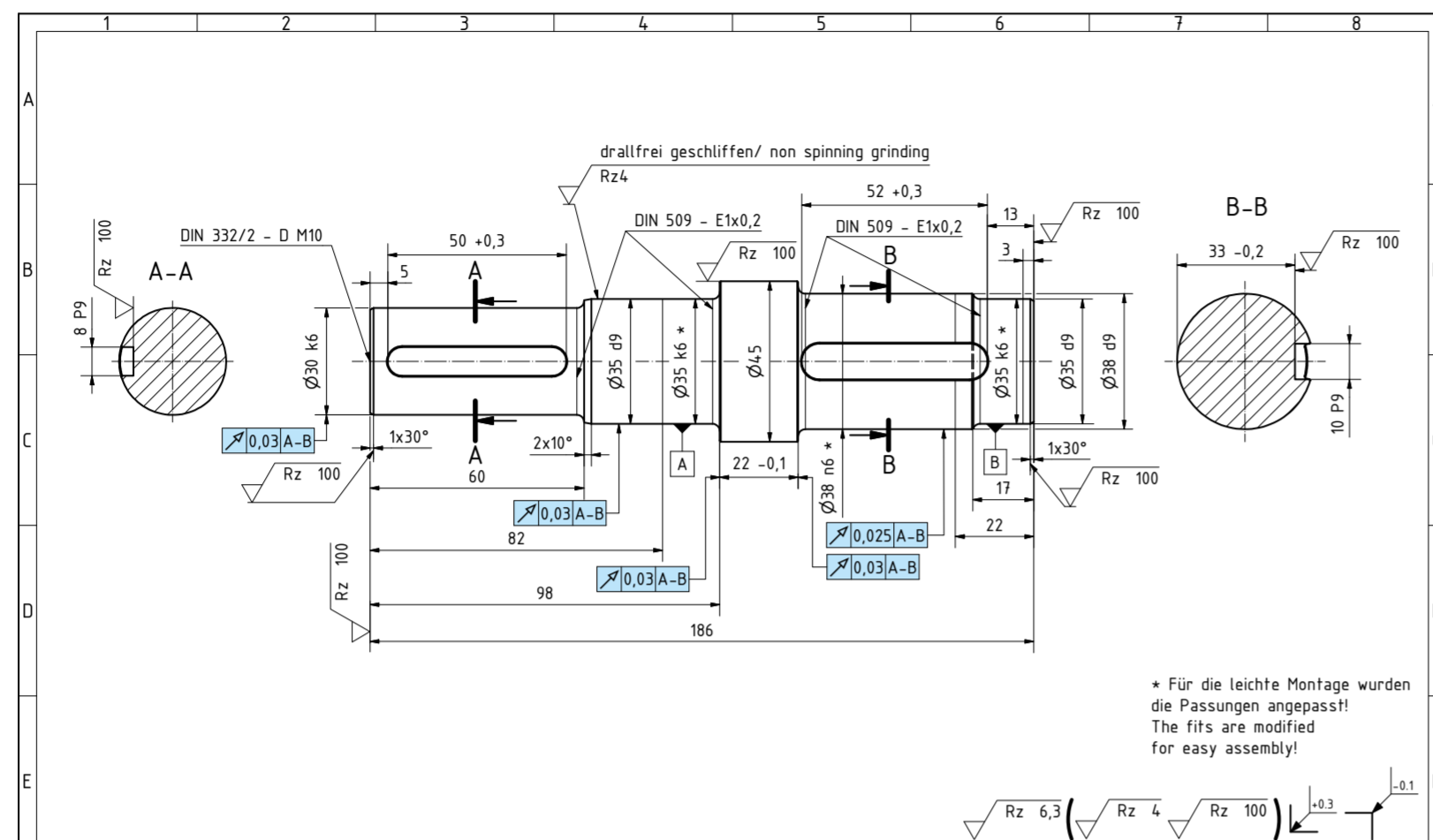

Main GPS standards for the geometrical definition of a workpiece	
Complementary GPS standards	
DIN EN ISO 8062-3	General dimensional and geometrical tolerances and machining allowances for castings
DIN EN ISO 1660	Geometrical tolerancing – Profile tolerancing
General GPS standards	
DIN EN ISO 14405-1; -2; -3	Dimensional tolerancing – Linear sizes; Dimensions other than linear or angular sizes; Angular sizes
DIN EN ISO 286-1; -2	ISO code system for tolerances on linear sizes – Tolerances, deviations and fits, tables
DIN EN ISO 1101	Geometrical tolerancing – Tolerances of form, orientation, location, run-out
DIN EN ISO 21920-1; -2; -3	Surface characteristics of profiles: Specification of surface texture, terms, definitions and parameters, specification operators
Fundamental GPS standards	
DIN EN ISO 8015	Fundamentals – Concepts, principles and rules
DIN EN ISO 14638	Matrix model

Maßstab/Scale: 1:1	Position/Item: 204	Material: 1.0503 C45
Technische Zeichnung/Technical drawing	Erstellt/Drawn by: Dr. F. Müller	Geprüft/Checked by: Smollich
Freigegeben/Released	Freigegeben/Approved	Freigegeben/Approved
Abtriebswelle/Output shaft	424.03020A0022	171



MT 123 Assembly exercise: spur and worm gear

Matrix model of the ISO GPS standards	Chain links						
	A	B	C	D	E	F	G
Geometrical properties	Symbols and specifications	Requirements for geometric elements	Characteristics of geometric elements	Conformity and non-conformity	Measurement	Test equipment	Calibration
Size dimension							
Gap							
Form							
Orientation							
Location							
Run-out							
Surface characteristics: profile							
Surface characteristics: area							
Surface imperfection							
	Specification			Verification			

The 6 sample test objects from the PT 102 to PT 109 practice kits offer many possibilities to deal concretely with the various GPS specification elements. This is done in a particularly broad and practical manner with the PT 107 and PT 108 practice kits.

The two main processes, **specification process** and **verification process**, belong together to produce a defect-free component. This relationship is clearly illustrated in the matrix model.

Our DigiSkills 2, dimensional metrology learning project works with the full scope of the matrix.

Another exercise variant:

This is the production drawing for the flange housing from the MT 123 spur and worm gear assembly exercise. At the same time, this component also represents the test object in the PT 107 practice kit.

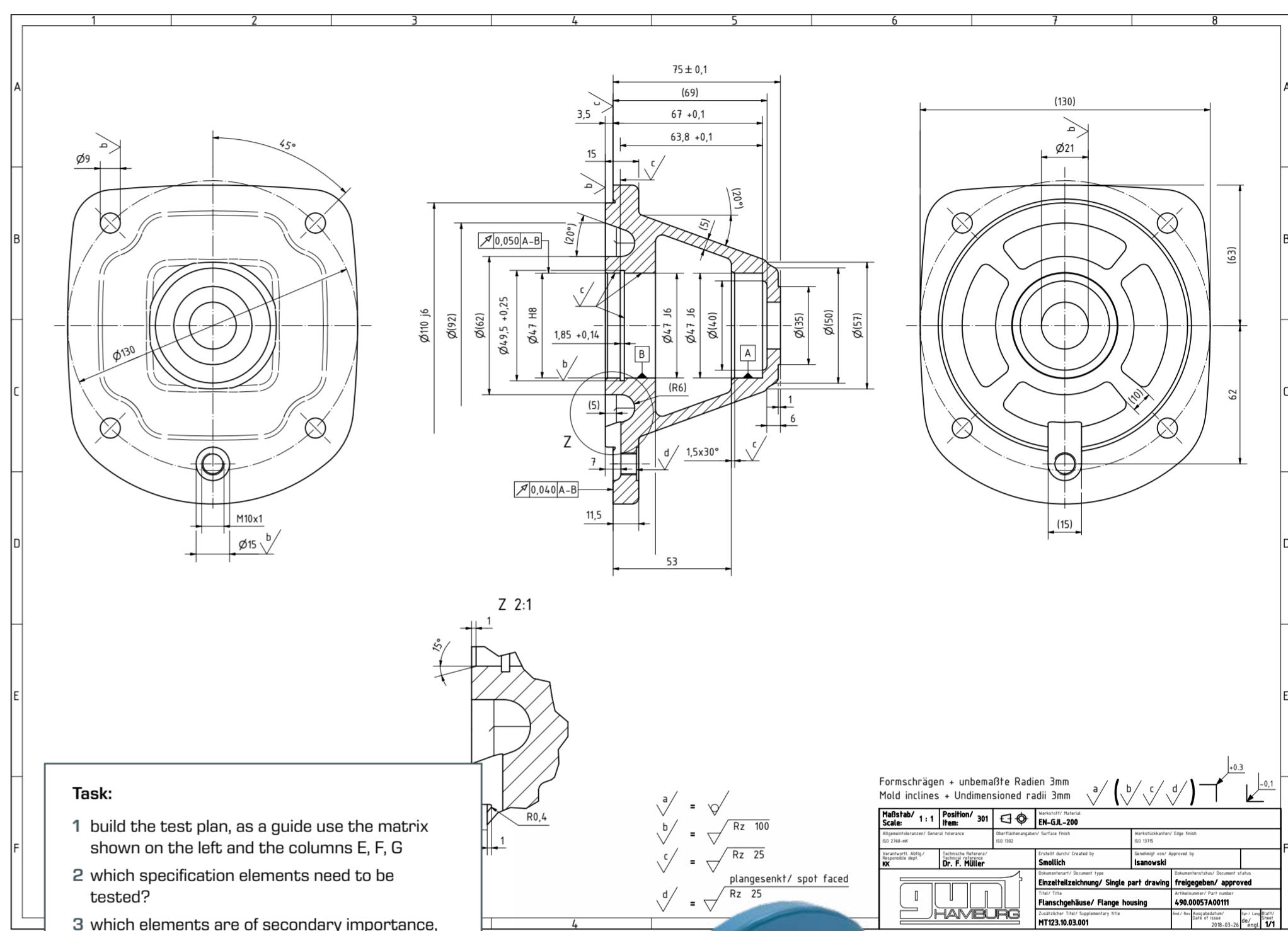

Task:

- 1 build the test plan, as a guide use the matrix shown on the left and the columns E, F, G
 - 2 which specification elements need to be tested?
 - 3 which elements are of secondary importance, e.g. for the function?
 - 4 what test equipment is required?
 - 5 how can the test object be stored safely and brought into position for the respective tests?
- These and many more drawings can be found in the GUNT Media Center.



Suggestions for further exercises described on the following pages

Finally, you will find some suggestions for topics or exercises designed to help you and your students/trainees think "outside the box" and step off the strict "technology path". You can use the PT 102 to PT 109 practice kits from GUNT for all exercises.

3 | Example presentation of selected exercises

3.4 | Software-supported analysis

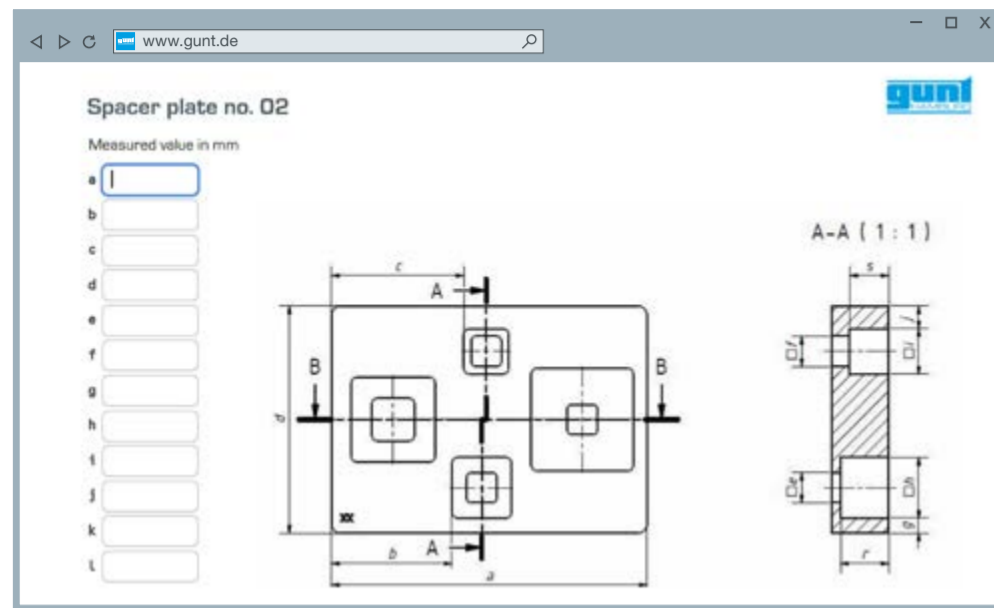

The "spacer plate" test object from the PT 102 practice kit has 21 lengths – marked a to u – to be tested. You will find 10 identical test objects in the practice kit, which are marked with ordinal numbers 1 to 10. Each test object has to be identified as GOOD or REJECT.

A graphical view can be used to illustrate the overall picture.

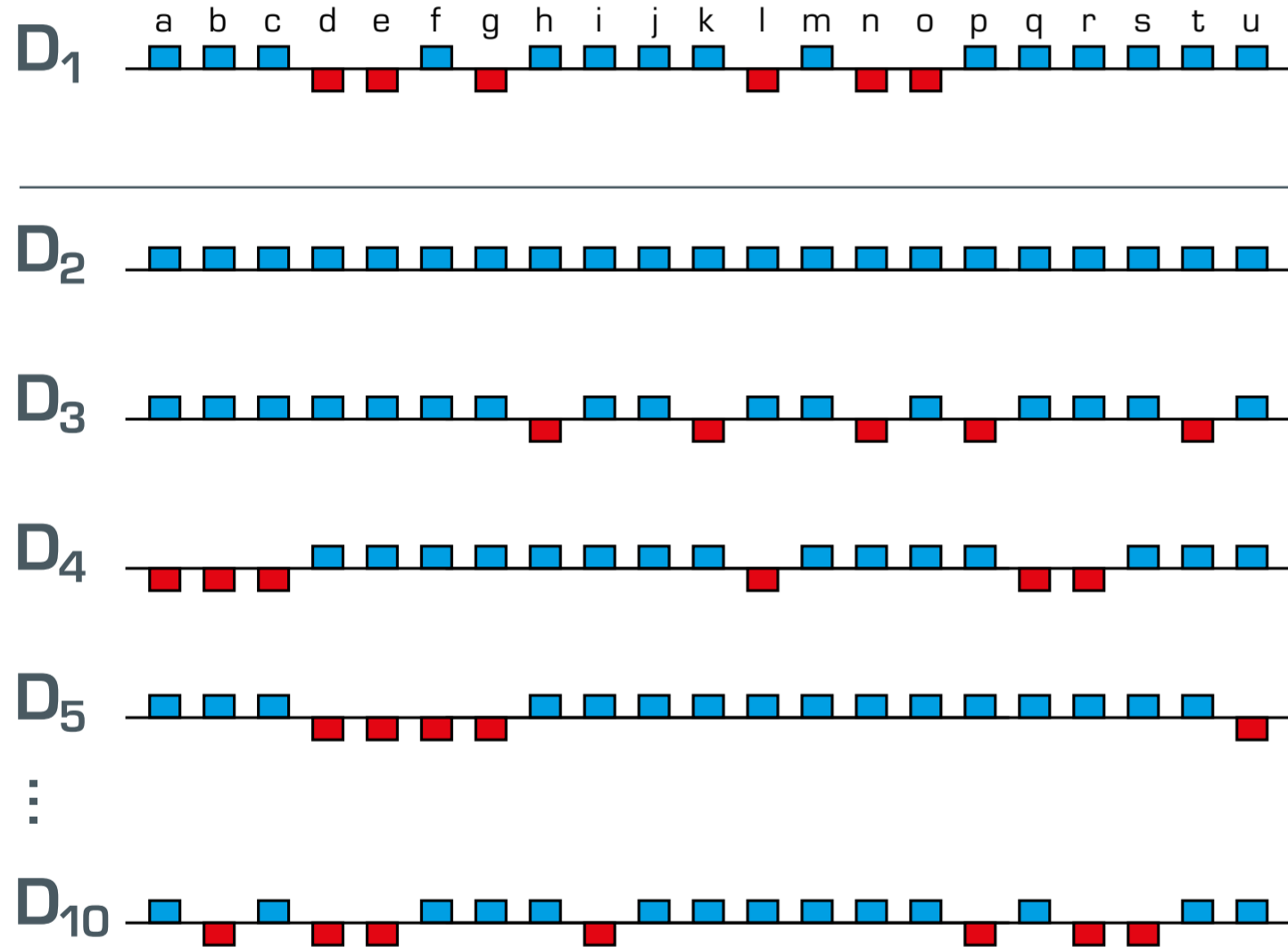

Task:

Each trainee creates a graph for their test object. Then the graphs for all 10 test objects of the practice kit are arranged one below the other.

In this way it is possible to see at a glance where the variances are too big, i.e. where there is a REJECT. Possible discussions include:

- 1 does a variance occur systematically within a production batch? does it always occur at a certain position?
- 2 do deviations occur "scattered", i.e. sometimes here and sometimes there? in other words, random errors?
- 3 and how can the production be assessed? If necessary, where would you have to start in order to get more reliable results?
- 4 what does the term validation mean?

D₁ – D₁₀ spacer plate from the PT 102 practice kit
■ good ■ reject a–u dimensions

Learning objectives – Skill modules

Development of digital skills	Traditional, technical content
<ul style="list-style-type: none"> ■ illustrate technical issues with graphics ■ use simple graphics programs or standard MS Office tools ■ present and communicate technical content using digital tools 	<ul style="list-style-type: none"> ■ familiarisation with the assessment criteria for GOOD and REJECT ■ understand and explain common terms of conformity and validation use in testing ■ assess variances: systematic errors, random errors ■ subjective/objective testing ■ measuring/gauging sense perception

3.5 | Processing technical relationships digitally

The MT 123 spur and worm gear assembly exercise is part of the overall DigiSkills 2 concept. The PT 107 and PT 108 practice kits use parts of the MT 123 gear as test objects. The purchase of the MT 123 assembly kit gives you full access to the GUNT

Media Center. There you will find extensive digital materials that provide you and your students or trainees with answers to every question and offer the full scope in terms of media technology.

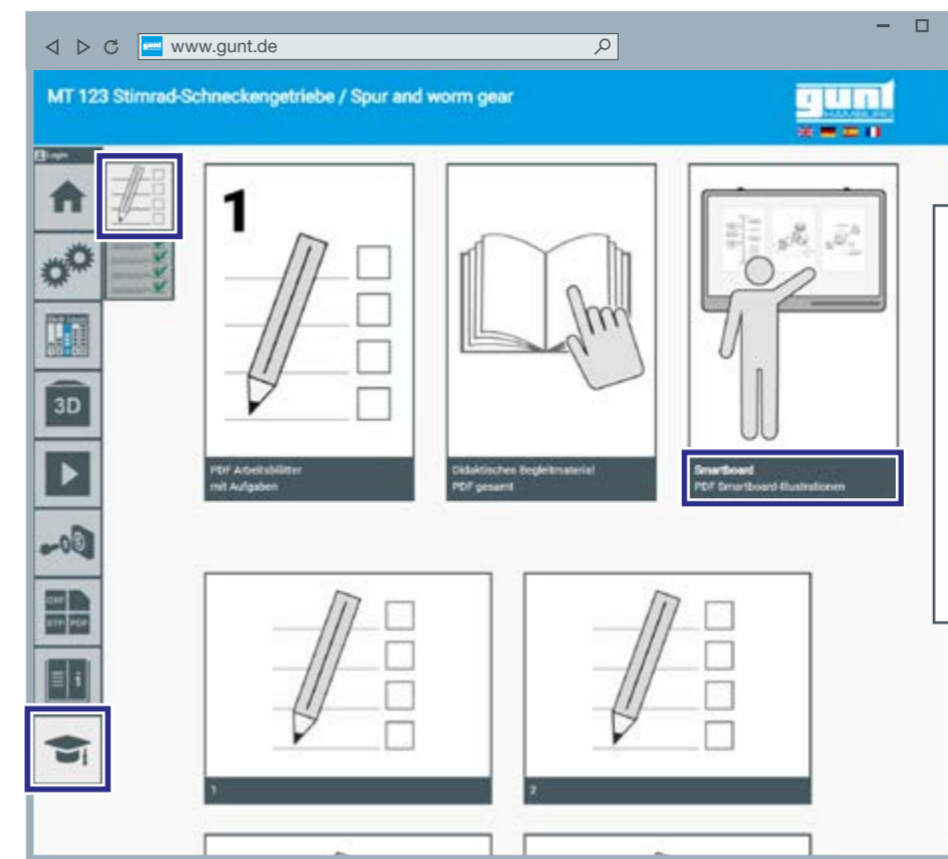

Task:

Which different sealing elements are used in the spur and worm gear unit to ensure that the internal oil filling is reliably sealed?

- 1 how do the individual sealing elements work?
- 2 what technical terms are used to describe them?
- 3 are there standards for individual sealing elements?
- 4 what materials are used for the different sealing elements?
- 5 present the results to the group.

3.6 | Familiarisation with sealing elements

Sealing elements are studied by means of the MT 123 spur and worm gear assembly exercise. This can then be used to formulate an independent presentation task for the students/trainees.

These examples show how much is possible with the GUNT Media Center. The information contained can, for example, be incorporated into the trainees' presentation. There is much more to discover in the GUNT Media Center.

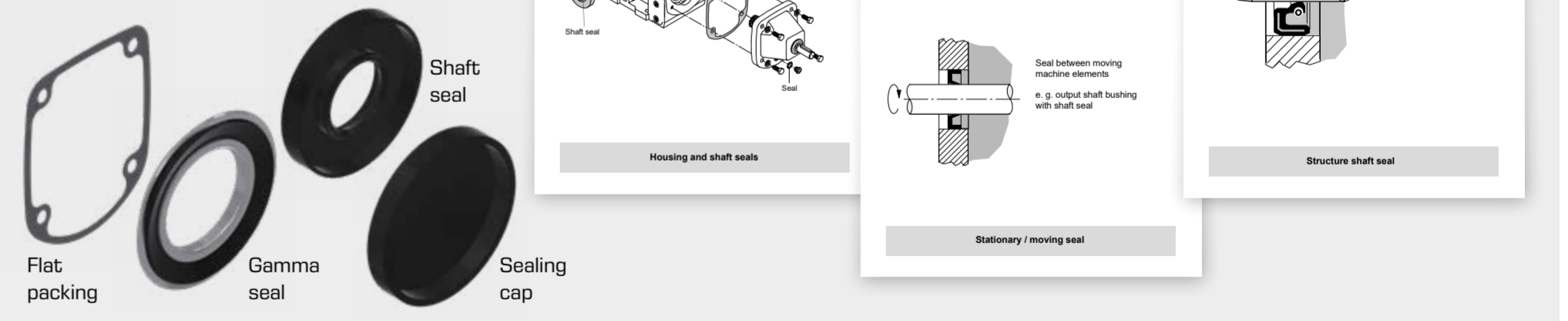

Learning objectives – Skill modules

Development of digital skills	Traditional, technical content
<ul style="list-style-type: none"> ■ independent search for and retrieval of information via web and/or portals ■ process, present, communicate technical relationships for a presentation using digital tools such as Word, PPT, video, etc. ■ be familiar with and use document and file formats ■ store, save, protect, copy, print, send files 	<ul style="list-style-type: none"> ■ overall structure and function recognise the MT 123 spur and worm gear unit ■ recognise that the gear is supplied with oil during operation and how the oil from the oil sump is distributed to where it is needed ■ recognise how the housing parts and the shaft outlets are sealed against oil leakage

3 | Example presentation of selected exercises

3.7 | Technical terminology

It is important for every skilled worker or engineer to be familiar with and comfortable using the correct technical terminology.

Vocational training can also help in this regard. Working with the GUNT-DigiSkills learning projects gives you every opportunity to learn technical terminology in a practical way and in a technical context. You and your students/trainees will enjoy it, develop motivation and learn a lot.

This is the exploded view for the MT 123 spur and worm gear assembly exercise. The item numbers are the part numbers that can also be found in the storage system. All components considered in the tasks are real and can be held in your hand.

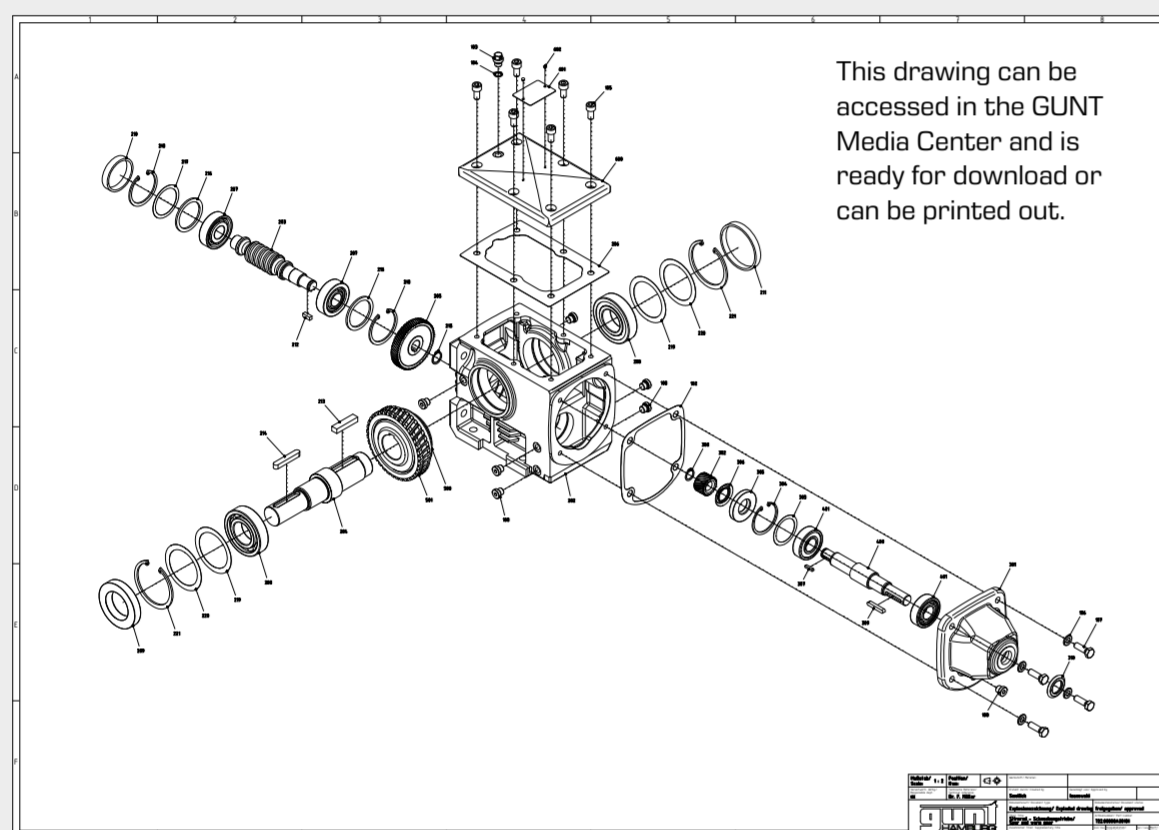

This drawing can be accessed in the GUNT Media Center and is ready for download or can be printed out.

- Task:**
- 1 work with the GUNT Media Center, with search engines like Google, Bing, etc. with online dictionaries or with online textbooks
 - 2 create tables for technical terms as shown here

Part number	German term	English term	Notes
722.00000A00023	Schneckenrad	Worm wheel	
219.00000A00112	Verschlusskappe	Sealing cap	

The GUNT Media Center

All contents and information in drawings and parts lists are available in English/German at a minimum. In addition, the GUNT Media Center allows you to choose Spanish/English or French/English. You do not have to register for this, the content is available to you at no extra cost.

Pos. Item	Menge Quantity	Einheit Unit	Benennung Description	Nummer/Name Draw no./Standard	Arbeitsnummer Part number	Bemerkung Comment
300	1	Stk. pce.	Baugruppe Antriebswelle/Component group drive shaft	MT123.00.04.000	722.00000A00018	
301	1	Stk. pce.	Flanschgehäuse/Flange housing	MT123.10.03.001	490.00057A00101	EN-GJL-200
302	1	Stk. pce.	Antriebsritzel/Drive pinion	MT123.10.03.002	4.10.30612A00101	16MnCr5SG
303	2	Stk. pce.	Passscheibe/Shim ring	DIN 988	209.00000A00124	
304	1	Stk. pce.	Sicherungsring/Circus ring	DIN 472	204.00000A00124	
305	1	Stk. pce.	Wellendichtring/Shaft seal	ISO 6794	214.00000A00102	
306	1	Stk. pce.	Gammerring/Gamma seal	RC 20x35x4 OD	214.00000A00106	Eriks
307	1	Stk. pce.	Passfeder/Feather key	DIN 6885	203.00000A00108	
308	1	Stk. pce.	Sicherungsring/Circus ring	DIN 471	204.00000A00120	
309	1	Stk. pce.	Passfeder/Feather key	DIN 6885	203.00000A00109	
310	1	Stk. pce.	Gammerring/Gamma seal	WFWA 20x35x4-N	214.00000A00107	Eriks

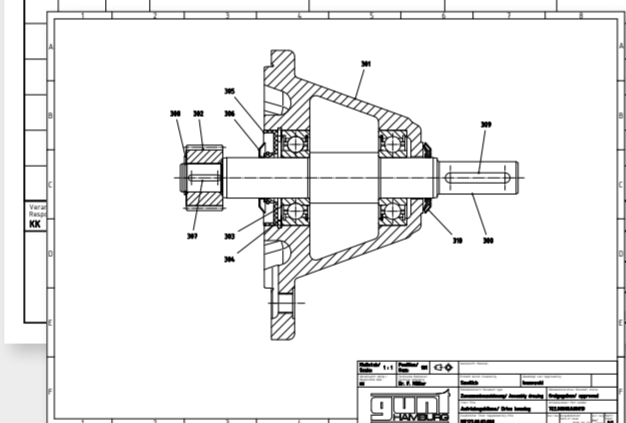

Task: Complete the E-Learning course for PT 102 in English. As an additional task, students/trainees can work on the worksheet as well.

3.8 | ...a trainee's thoughts

I am Jessica. I am 21 years old and I a technical product designer in my third year of training.

My training company – a large medical product manufacturer – sent me to the GUNT Technical Academy for an additional qualification. It covered quality inspection, quality management, ISO GPS and testing technology, especially dimensional metrology.

The course was held entirely in English. I had a lot of fun and I also learned a lot. In our small learning group, it was always about technology. Everything was very practical and there were lots of exercises.

I almost didn't notice that I was learning another language. I enjoyed every hour I spent in the international environment of the GUNT Technical Academy.

My training company was overjoyed with my certificate.

4 | Product list and tender specifications

Product list

The following equipment is necessary for a fully equipped laboratory or workshop area:

Dimensional metrology practice kits, fundamentals

- 1 x PT 102 Dimensional metrology, spacer plate
- 1 x PT 104 Dimensional metrology, angle piece
- 1 x PT 105 Dimensional metrology, shaft
- 1 x PT 109 Dimensional metrology, hub

Dimensional metrology practice kits, industrial level

- 1 x PT 107 Dimensional metrology, flange housing
- 1 x PT 108 Dimensional metrology, output shaft

Assembly kits

- 1 x MT 123 Assembly exercise: spur and worm gear

Cutaway models

- 1 x MT 110.10 Cutaway model: spur and worm gear

Tender specifications

Here we provide text describing the overall concept of **GUNT-DigiSkills 2**. The complete tender specifications for individual products can be found on the GUNT website, on the page for the specific product. The texts provided there are ideally suited for constructing a call for tenders, together with the text you will find here. We are always available to help you set up a call for tenders.

The DigiSkills 2 learning project provides comprehensive exercises on dimensional metrology. The learning level ranges from "beginner" to "expert". The learning project includes six didactically related practice kits. Of these, four practice kits are intended for the development of fundamentals and two for a deeper technical understanding.

The four practice kits for the development of fundamentals

- PT 102 Dimensional metrology, spacer plate
- PT 104 Dimensional metrology, angle piece
- PT 105 Dimensional metrology, shaft
- PT 109 Dimensional metrology, hub

contain 10 almost identical test objects, each of which, however, has small, individual dimensional variances. The target specification is given by a production drawing which follows the valid ISO GPS standards.

The storage system, consisting of a plastic case with foam inlay, contains the test objects as well as the test equipment required for an exercise. All test objects are made of stainless steel.

Two additional practice kits contain original components from the MT 123 spur and worm gear assembly exercise:

- PT 107 Dimensional metrology, flange housing
- PT 108 Dimensional metrology, output shaft

One test object each is assumed here. The test objects are real, industrially manufactured components that are functionally related.

The overall concept of DigiSkills 2 includes the MT 123 spur and worm gear assembly exercise, from which the test objects for the PT 107 and PT 108 practice kits originate.

For each PT practice kit that is part of the DigiSkills 2 learning project, there is access to the online GUNT Media Center portal. The access licence to the GUNT Media Center is acquired when you purchase the hardware and is not subject to any further conditions or restrictions.

Extensive digital materials are available in the GUNT Media Center: standard-compliant drawings of the test objects, assembly and disassembly videos, original data sheets for the test equipment, worksheets and solutions.

Each practice kit

- PT 102 Dimensional metrology, spacer plate
- PT 104 Dimensional metrology, angle piece
- PT 105 Dimensional metrology, shaft
- PT 109 Dimensional metrology, hub

provides access to a specific E-Learning course. This is used to work through the fundamentals, complete exercises and carry out knowledge tests.

In addition to the achievement of systematic and versatile learning objectives of dimensional metrology in the area of conventional, technical content, the courses develop comprehensive digital skills through vertical integration and a focus on projects. With the complete GUNT-DigiSkills 2 dimensional metrology system, the following building blocks for the development of digital competences must be achievable:

- using web portals as a source of information: data from the GUNT Media Center, accessed via QR code or link
- familiarisation with various practical file formats: PDF, DXF, STP, etc.
- use standard business software, e.g. Office packages, ERP systems, Computer Aided Design (CAD)
- create or edit drawings, protocols, work plans
- use digital learning media, e.g. web-based training (WBT)
- research information sources and obtain information from digital networks and evaluate information from the Internet, portals, platforms
- familiarisation with digital test equipment with data interfaces
- media technology, presentation methods
- paperless processing of exercises and associated protocols, interactive PDF templates, email communication, video conferencing

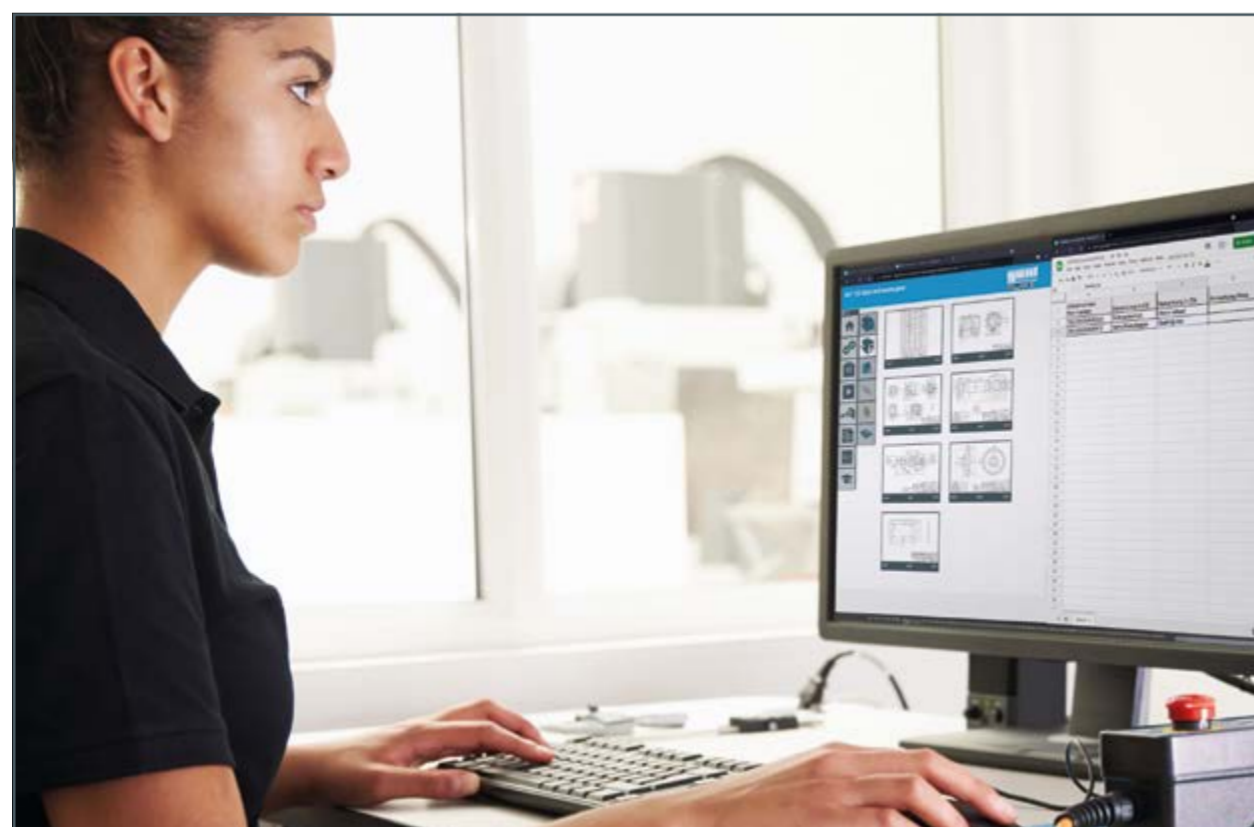

5 | Summary – Outlook

With this didactic concept for the **GUNT-DigiSkills 2** learning project, we have made a proposal of what modern training in technical professions can look like when traditional and the latest learning objectives is developed in a digital environment.

The five exercises described here are just the beginning. Much more is possible. And this will be easy for you and your students/trainees if you follow our methods.

You will immerse yourself in thinking and working in the context of **digitalisation** and **Industry 4.0**.

GUNT-DigiSkills learning projects – common features

Our learning projects provide targeted and comprehensive support for the development of the new profession profiles **Digitalisation of Work** and **Industry 4.0** for metalworking and electrical professions. GUNT-DigiSkills learning projects:

- represent industrially-relevant procedures/processes on which digital competences can be developed in the same way as traditional learning objectives
- are planned carefully and comprehensively from a didactic perspective and provide teachers with a directly implementable concept
- are designed to be tangible, practical and take learners and teachers on the journey from the outset
- foster direct participation and motivation; a sense of achievement and visible learning progress are ensured at all times and at every step
- are scalable in demand and scope, from basic to complex
- have an open design: your own approaches can be integrated, changes and expansions are possible
- are interdisciplinary, practical, process-oriented and totally digital; that is why they bear the name **GUNT-DigiSkills**, but remain real-world practice: for doing, for touching

The basis is the **real world**; the paths to the modern world of work are **virtual** and **digital**.

GUNT-DigiSkills – different levels of requirements



- 1 Engineering drawing**
- 2 Dimensional metrology**
- 3 Preventive maintenance**
- 4 Experimental plants**
- 5 Robotics and automation**

What our customers say

Our exercises on dimensional metrology are also tried and tested and in demand at colleges and universities.

Often our students do not have any practical experience in the core curriculum. And of course even less suitable practical professional skills. We get a lot of response and enthusiasm from our students when we offer laboratory exercises in which GUNT practice kits PT 102 to PT 109 are used in the context of dimensional metrology.

We know that the practice kits on the topic of dimensional metrology are tailored to vocational training in the various apprenticeships in the metalworking sector.

The clearly structured teaching material, the E-Learning course and access to the GUNT Media Center allow our students to learn independently. Of course, we also always have an eye on the progress and tools of digitalisation, which are crucially important for our students. The GUNT systems are also state-of-the-art.

It is also perfect for us that a practice kit contains everything you need to get started with the exercises straight away.

As always, the quality of GUNT's products is outstanding.



We have several years' experience with GUNT's didactic training systems. We follow and see the modernisation and adaptation of GUNT's systems to today's requirements in the direction of Industry 4.0 and digitalisation.

We have been using dimensional metrology from GUNT since pre-digital times. It is therefore all the more important for us to see the modernisation push of GUNT's systems and to achieve benefits and progress from this in our teaching. The new GUNT training systems for dimensional metrology ideally combine the necessary conventional learning objectives with the modern possibilities to train digital working methods and to offer and develop digital skills for our students. This is specifically required by our new curricula.

We are very pleased to see that our students approach the exercises with lots of motivation and achieve very good learning results.



Vocational School Eschwege, Germany

The GUNT-DigiSkills learning projects

Digitalisation of the world of work – new requirements for the professional world

How to achieve the digital transformation to Industry 4.0

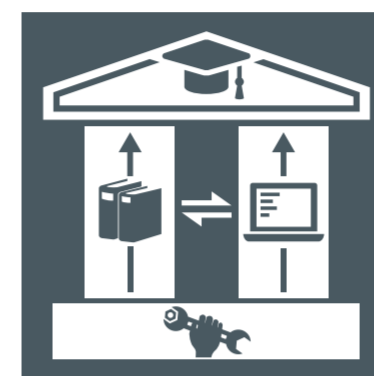

All GUNT-DigiSkills learning projects follow the model of **hybrid learning objective development**: traditional subject-specific learning objectives are achieved in parallel and integrative with the development of digital skills. Always in a practical environment.



Prof. Dr. em. Jörg Peter Pahl, TU Dresden, Institute for Vocational Education

With the GUNT-DigiSkills learning projects, GUNT has introduced a groundbreaking didactic concept that perfectly meets today's demands for the digitalisation of the world of work.

The new concept will – as can be assumed – be well accepted in the training and teaching process.

Main features are:

- vertical integration of competence development
- hands-on learning environment
- learning situations are always real, but digitally supported throughout

DigiSkills learning project no.	Subject area	Learning objective areas/ Features	Focus
1	Engineering drawing	 <ul style="list-style-type: none"> ■ fundamentals of engineering drawing ■ geometric models, functional models ■ Geometrical Product Specifications (GPS) ■ constructive thinking, machine elements, materials 	Metalworking professions
2	Dimensional metrology	 <ul style="list-style-type: none"> ■ fundamentals of dimensional metrology: testing, measuring, gauging ■ familiarisation with test equipment ■ Geometrical Product Specifications (GPS) ■ surface marking, fit systems 	Metalworking professions
3	Preventive maintenance	 <ul style="list-style-type: none"> ■ predictive maintenance, condition monitoring ■ assembly and disassembly, functional testing, commissioning ■ distinguish between production/drawing parts and standard parts ■ machine elements, materials 	Metalworking and electrical professions
4	Experimental plants	 <ul style="list-style-type: none"> ■ study and compare the operating behaviour of different system elements ■ record characteristic curves ■ determine efficiency ■ parallel or series connection of pumps 	Metalworking and electrical professions
5	Robotics and automation	 <ul style="list-style-type: none"> ■ mechanics, hydraulics, pneumatics, electrics ■ control system, PLC programming ■ sensors and actuators ■ system integration ■ process integration 	Mechatronics, Metalworking and electrical professions



Contact

G.U.N.T. Gerätebau GmbH
Hanskampring 15 - 17
22885 Barsbüttel
Germany

+49 40 67 08 54 - 0
sales@gunt.de
www.gunt.de

Imprint

© 2022 G.U.N.T. Gerätebau GmbH. Any reuse, storage, duplication and reproduction – even in extracts – is prohibited without written approval. GUNT is a registered trademark. Our products are protected by and subject to copyright law.

No warranty shall be assumed for printing errors. Subject to change without notice.

Image credits:
G.U.N.T. Gerätebau GmbH,
manufacturer photos, Shutterstock.
Design & typesetting:
Profisatz.Graphics, Bianca Buhmann,
Hamburg.
Printed on chlorine-free, environmen-
tally friendly paper.



Visit our website
www.gunt.de